



100129

Fender Mounting Instructions for MIN4050, MIN950 & MIN1550 Fenders

STEP 1

- A. Unpack all cartons and lay out parts.
- B. Compare the parts with hardware kit 100129 as shown in Figure 1.

PART NUMBER	DESCRIPTION	QTY
PB5015	BRKT,5015,STL,SWVL,4.25,BLK	2
I62C450BFL8/RBZFT	HDWR,HHCS,RBZ,FLNG,5/8-11X4.5	2
I62CNCG/RBZ	HDWR,NUT,RBZ,FLNG-LOCK,5/8-11	4
PB1/2"SPACER	HDWR,SPCR,PE,.5	8
100133	BRKT,5010,PP,TPRD,26,SLVMIR	2
100366	BRKT,BLOCK,PP-MICA,BLK	2
I31C300BSF	HDWR,HHCS,ZINC,SERR,5/16-18X3	8
I31C100BSF	HDWR,HHCS,ZINC,SERR,5/16-18X1	12
I31N150WFEZ	HDWR,WSHR,ZINC,5/16X1.5	12
I31CNCFZ	HDWR,NUT,FLNG-LOCK,5/16-18	34
PB5067	BRKT,5067,STL,CNTR,ANGL	2
I62C250BFL8/RBZ	HDWR,HHCS,RBZ,FLNG,5/8-11X2.5	2
PB5069	BRKT,5069,PE,CNTR,.5	2
I31C125BSF/RBZ	HDWR,HHCS,RBZ,SERR,5/16-18X1.2	8
I31CNCF/RBZ	HDWR,NUT,RBZ,FLNG-LOCK,5/16-18	8
PB5071	BRKT,5071,PE,CNTR,ANGL	2
I31C125BSF	HDWR,HHCS,ZINC,5/16-18X1.25	14

100129 Mounting Kit

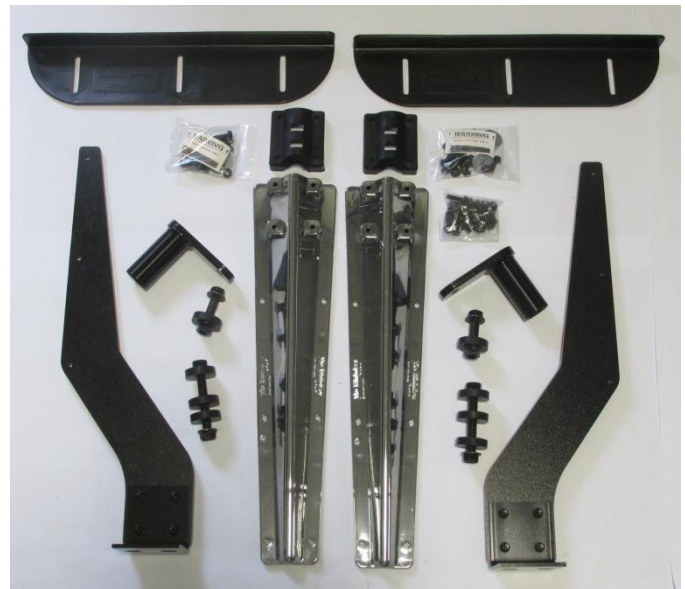

Figure 1

WARNING:

DO NOT APPLY CHROME POLISH, METAL POLISH, OR ANY TYPE OF BUFFER TO MINIMIZER SILVER MIRROR PRODUCTS. USING ANY OF THE ABOVE ITEMS WILL VOID PRODUCT WARRANTY.

- Protective wrap has been applied to protect the brackets during shipment.
- Wash brackets with mild soap and water.
- Do not wipe the mirror finish when it is dry or with a dry cloth. Only use a clean, damp microfiber cloth when wiping or drying your Minimizer Silver Mirror products.
- Do not use any abrasive cleaners or pads.
- Care for Minimizer Silver Mirror products as you would care for an automotive paint finish.
- To maintain the luster of Minimizer Silver Mirror products, apply an off the shelf wax/polish combination that you would use on the painted surfaces of your automobile. Follow the manufacturer's instructions on the product of your choice e.g. "Meguiars", "Mothers Gold", "Blue Coral".

STEP 2

- A. Measure the suspension travel. This measurement is used to determine the distance between the fender and the wheel.
 - a. For air suspension systems, let the air out of the air bags.
 - b. For spring systems, measure from the stops on the springs to the bottom of the frame.

NOTE: For air suspensions with travel exceeding 6”:

In some cases a travel stop may need to be installed to prevent such large gaps between the fenders & tires. This will help with alignment and 5th wheel plate clearance. (Please call *Minimizer @ 800-248-3855* for questions regarding this issue).

- B. Gap the fenders $\frac{3}{4}$ ” over the maximum travel point of the suspension system. The goal is to make sure the fender does not rub on the tire. A gap larger than $\frac{3}{4}$ ” may be necessary if using worn tires.

TIP: Establish the $\frac{3}{4}$ ” minimum gap required in Step 2B.

- a. For an air suspension system, place a $\frac{3}{4}$ ” board on top of the tires after the air has been let out of the airbags (Figure 2). Place the fender on top of the board.
- b. For a spring suspension system, add $\frac{3}{4}$ ” to the measurement from Step 2A.

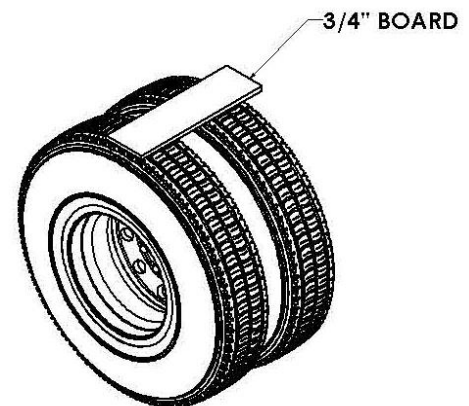

Figure 2

STEP 3

- A. Position the fenders exactly where they will be mounted.
 - a. Visually pick and mark the locations that the brackets will bolt to the frame.
- B. Try to use existing holes in the frame to bolt through. It is possible to remove any existing frame bolt and replace it with the supplied bolt in the bracket kit.
 - a. Splash guards are available if additional coverage is wanted with a half fender set (Figure 3).



Figure 3

C. Spacers are supplied to bring the steel swivel away from the frame in the event of any obstructions (Figure 4).

- c. The ideal setup is to mount the steel swivel directly to the frame.

NOTE: Use spacers only when necessary.

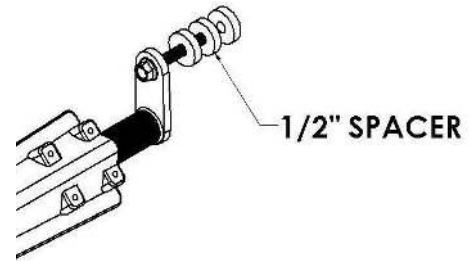

Figure 4

D. Install center bracket assembly (Figure 5).

- a. Try to use existing holes in the frame to bolt through. It is possible to remove any existing frame bolt and replace it with the supplied bolt in the bracket kit.

Recommended torque for the 5/8 x 2-1/2" bolt with washer is 110-115 ft-lbs

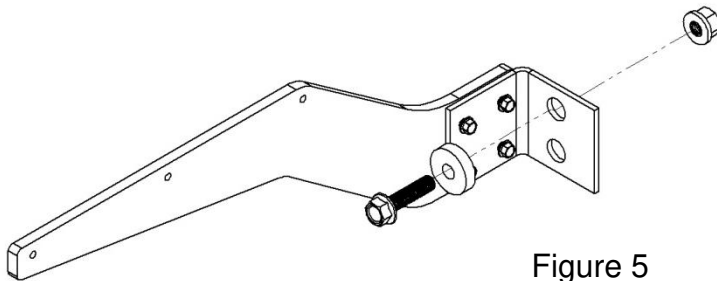

Figure 5

See IMPORTANT assembly Instructions for center bracket PB5069 & PB5067, last page of this form.

E. Install center bracket as close to the end of the fender as possible (Figure 6).

- a. Drill three 5/16" holes through the fender using the holes in bracket PB5069 as a guide.
- b. Use three 5/16" x 1 1/4" bolts to bolt the center bracket and fender together. **Recommended torque for all 5/16" hardware is 10-15 ft-lbs.**
- c. Use 5/16" body washers and 5/16" nuts provided with the kit on the inside of the fender.

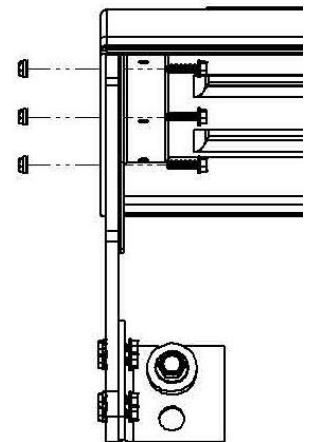

Figure 6

F. Some installations may not allow the center bracket to bolt through the end of the fender.

- a. In these cases use the plastic angle (PB5071) to connect the fender to the center bracket assembly (Figure 7).

- b. Use three 5/16" x 1" bolts, washers, and nuts to bolt PB5071 to the center bracket assembly. Do not tighten until these until the fender is level. **Recommended torque is 10-15 ft-lbs.**

Tip: PB5071 is also used as a height adjustment for the end of the fender.

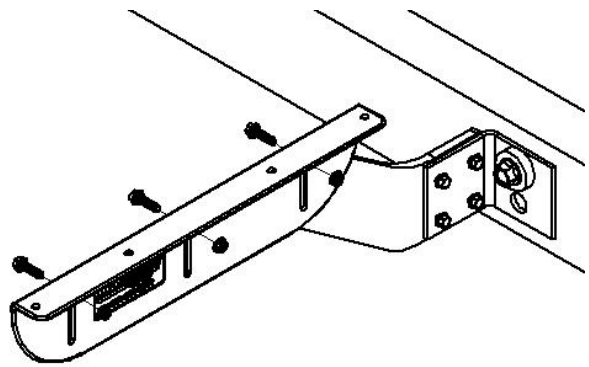

Figure 7

- G. Drill four 5/16" holes through the fender using the holes in bracket PB5071 as a guide (Figure 8).

- a. Install the 5/16" x 1 1/4" bolts through the bracket and into the fender.
- b. Use 5/16" fender washers and 5/16" nuts provided with the kit on the underside of the fender. Torque all 5/16" bolts to 10-15 ft-lbs.

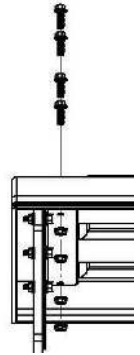

Figure 8

- H. If possible, position the mounting brackets so they are located within 15" of the bottom of the fender. This protects against wind blowing the leading edge of the fender back into the tire (Figure 9).

Tip If the front fender bracket is mounted higher than 15", refer to <http://www.minimizer.com/instructions.html> for further suggestions on adding additional support.

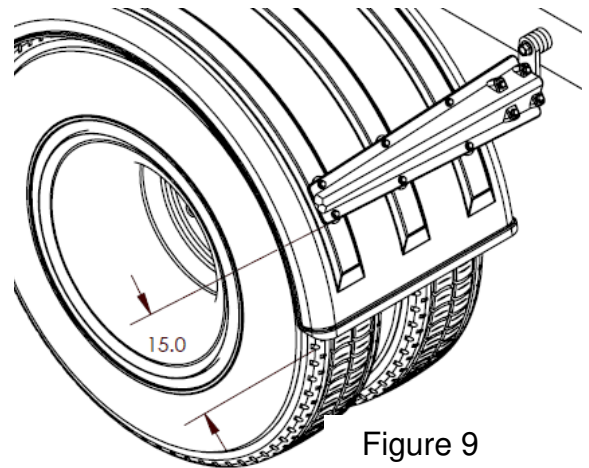

Figure 9

STEP 4

- A. Use four 5/16" x 3" bolts to attach the bracket (part number PB501026) and the backing block (part number PBLOCK) to the steel swivel (part number PB5015). As shown in Figure 10. **Make sure the pipe end of the PB5015 is fully engaged into bracket.**

TIP: USE CARE WITH POWER TOOLS AS OVER-TORQUING WILL CAUSE CRACKS IN THE BRACKET. RECOMMENDED TORQUE IS 10-15 ft-lbs.

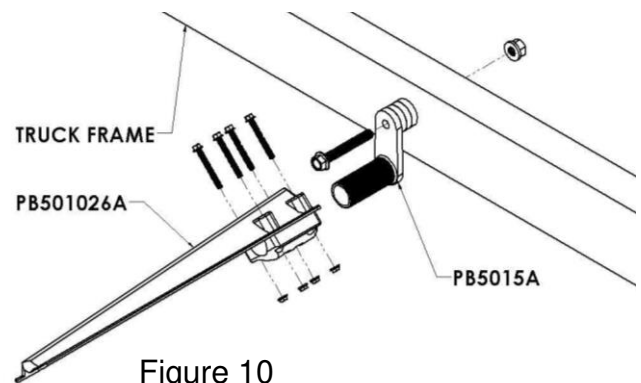

Figure 10

NOTE: DO NOT EXCEED RECOMMENDED TORQUE. THIS WILL VOID THE WARRANTY.

TIP: Do not completely tighten one side of the backing block before moving to the other side. Alternate tightening bolts as pictured in Figure 11. Make sure to only tighten halfway and then repeat the pattern in Figure 11 until backing block is tight.

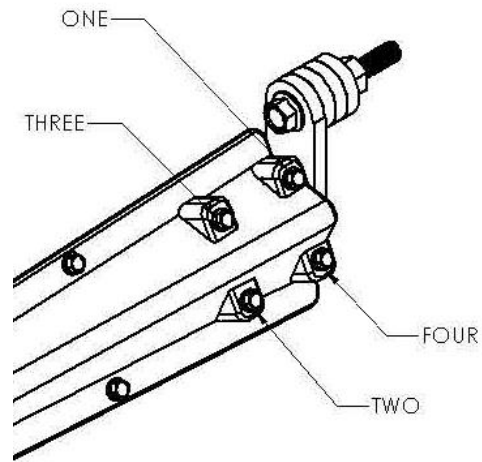

Figure 11

STEP 5

- A. Once the brackets are placed in position with the fender, securely tighten the 5/8" x 4-1/2" bolts that go through the PB5015 steel swivel to attach the swivel securely to the frame (Figure 12). **Recommended torque is 160-170 ft-lbs.**

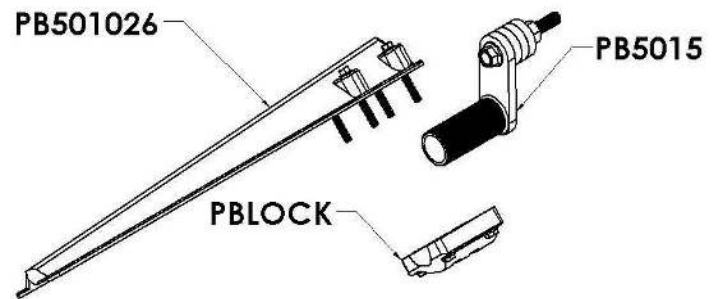

Figure 12

STEP 6

- A. Attach the bracket (PB501026A) to the fender.
 - a. Drill six 5/16" holes through the fender using the holes in bracket PB501026A as a guide.
 - b. Install the 5/16" x 1" bolts through the bracket and into the fender.
 - c. Use six 5/16" body washers and 5/16" nuts provided with the kit on the underside of the fender.
 - d. **Tighten the bolts to recommended torque of 10-15 FT-LBS.** Hand tightening with Torque wrench is recommended.

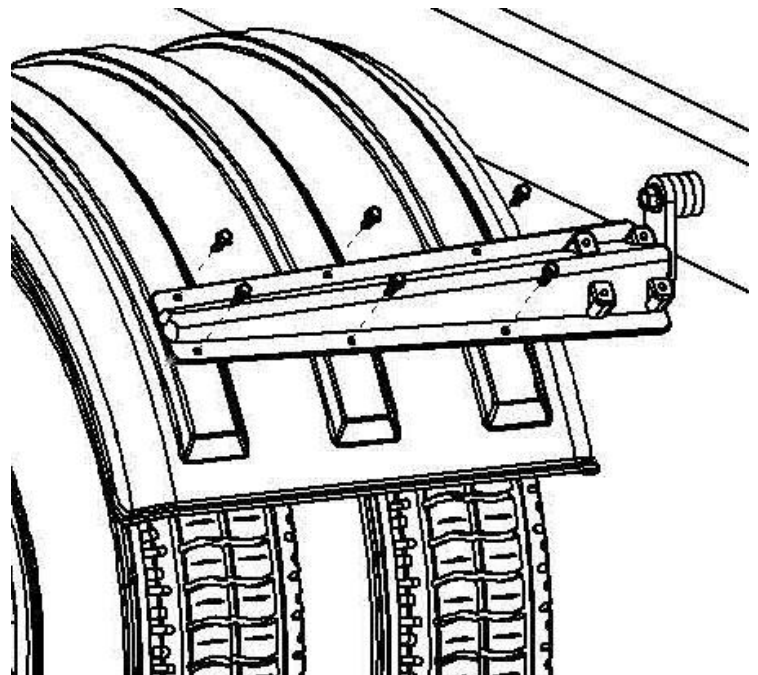

Figure 13

DO NOT EXCEED RECOMMENDED TORQUE.

- e. Make sure the fenders are square and aligned (Figure 13). Twists or bows in the fender will fatigue the material over time.

STEP 7

- A. For trucks with air suspension, raise and lower the suspension one final time to confirm that there is adequate clearance between the fenders and wheels.
- B. Recheck all brackets and bolts to ensure they are tightened to the recommended torque.

NOTE: ONCE FENDERS ARE IN SERVICE OCCASIONALLY CHECK TORQUE ON 5/8" X 4-1/2" HEX BOLTS IN THE FRAME TO MAKE SURE THEY DO NOT LOOSEN OVER TIME.

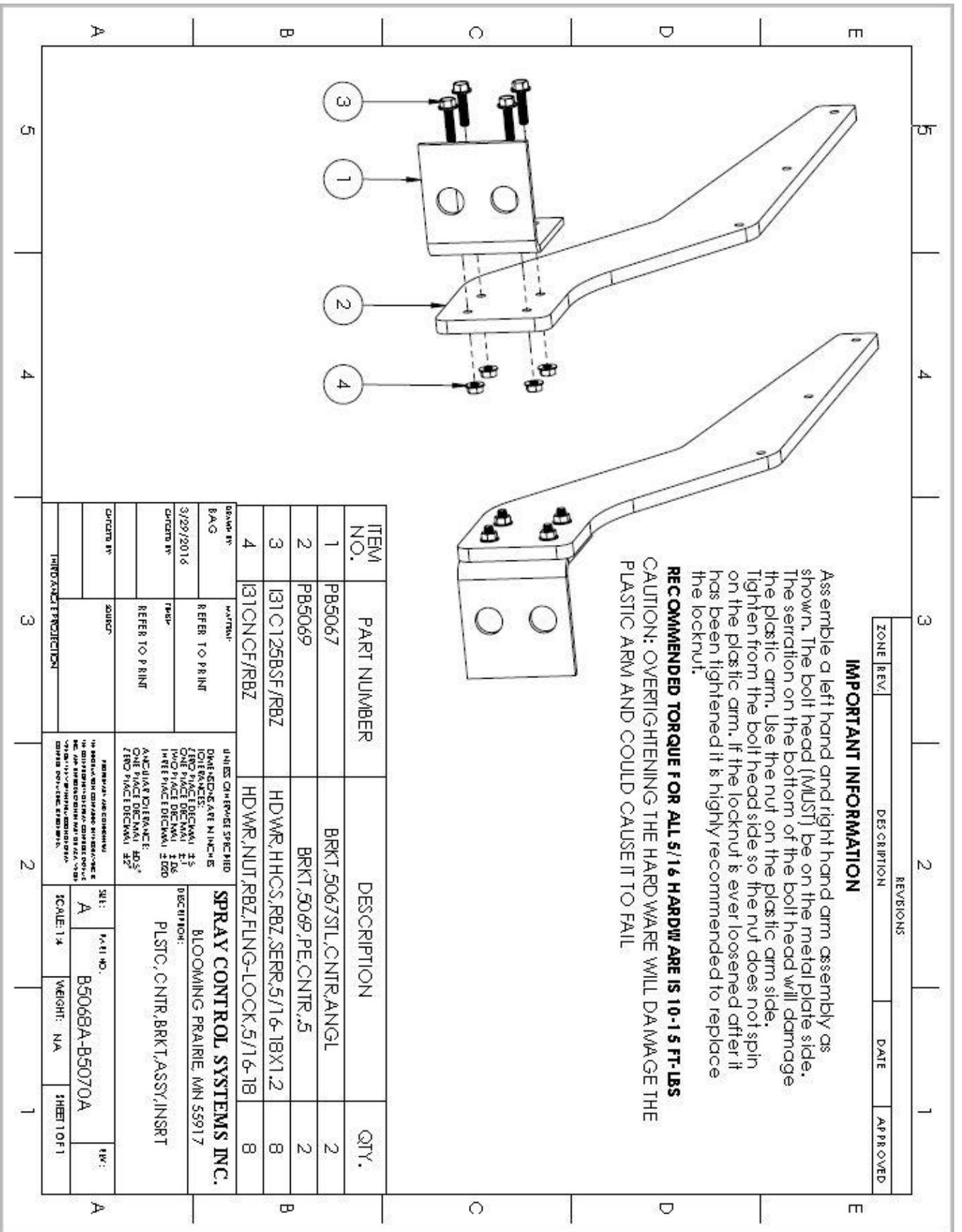

IMPORTANT INFORMATION

Assemble a left hand and right hand arm assembly as shown. The bolt head (MUST) be on the metal plate side. The serration on the bottom of the bolt head will damage the plastic arm. Use the nut on the plastic arm side. Tighten from the bolt head side so the nut does not spin on the plastic arm. If the locknut is ever loosened after it has been tightened it is highly recommended to replace the locknut.

RECOMMENDED TORQUE FOR ALL 5/16 HARDWARE IS 10-15 FT-LBS

CAUTION: OVERTIGHTENING THE HARDWARE WILL DAMAGE THE PLASTIC ARM AND COULD CAUSE IT TO FAIL

ITEM NO.	PART NUMBER	DESCRIPTION	QTY.
1	PB5067	BRKT,5067STL,CNTR,ANGL	2
2	PB5069	BRKT,5069,PE,CNTR,.5	2
3	I31C125BSF/RBZ	HDWR,HHQS,RBZ,SERR,5/16-18X1.2	8
4	I31CNCFRBZ	HDWR,NUT,RBZ,FLNG-LOCK,5/16-18	8

DESIGN BY:	DATE:	SCALE:	SHEET NO.:	TITLE:
BAC	3/22/2016	A	B5068A-B5070A	
CHKD BY:	TRSP	SCALE: 1:1	WEIGHT: N/A	SHEET 1 OF 1
CHKD BY:	REFER TO PRINT	SPRAY CONTROL SYSTEMS INC. BLOOMING PRAIRIE, MN 55917 PLSTC,CNTR,BRKT,ASSY,INSRT		
CHKD BY:	SOURC	UNLESS OTHERWISE SPECIFIED DIMENSIONS ARE IN INCHES DECIMALS: ONE PLACE DECIMAL .5 TWO PLACE DECIMAL .125 THREE PLACE DECIMAL .0625 ANGULAR DIMENSIONS: ONE PLACE DECIMAL .5° ZERO PLACE DECIMAL .2°		
MATERIALS AND COMPONENTS ARE THE PROPERTY OF SPRAY CONTROL SYSTEMS INC. AND ARE NOT TO BE REPRODUCED OR COPIED IN ANY MANNER WITHOUT THE WRITTEN PERMISSION OF SPRAY CONTROL SYSTEMS INC.				
IMPORTANT INFORMATION				