



B4850BTPA

Fender Mounting Instructions for MIN4050, MIN950 & MIN1550 Fenders

STEP 1

- A. Unpack all cartons and lay out parts.
- B. Compare the parts with hardware kit B4850BTPA as shown in Figure 1.

PART NUMBER	DESCRIPTION	QTY
PB5015	4.25" SWIVEL BRACKET	2
I62C450BFL8/RBZFT	5/8-11 X 4 1/2 HEX FLANGE BOLT	2
I62CNCG/RBZ	5/8-11 CLASS G FLANGE LOCK N	2
PB1/2"SPACER	1/2" POLY SPACER	6
PB501026	26.5 COMPOSITE TAPERED BKT	2
PBLOCK	COMP BRACKET BACKING BLOCK	2
I31C300BSF/RBZ	5/16- X 18 X 3 HEX WASH HEAD B	8
I31C100BSF/RBZ	5/16-18 X 1 HEX WASHER HEAD BL	12
I31N150WFEZ	5/16 X 1 1/2 FENDER WASHER	12
I31CNCF/RBZ	5/16-18 CLASS F FLANGE LOCK	20
PB5067	STEEL ANGLE FOR PB5069	2
I62C250BFL8/RBZ	5/8-11 X 2 1/2 HEX FLG BOLT BZ	2
I62CNCG/RBZ	5/8-11 CLASS G FLANGE LOCK N	2
PB1/2"SPACER	1/2" POLY SPACER	2
PB5069	COMPOSITE CENTER BRACKET	2
I31C125BSF/RBZ	5/16-18 X 11/4 HEX WASH HEAD B	8
I31CNCF/RBZ	5/16-18 CLASS F FLANGE LOCK	8
PB5071	COMPOSITE ANGLE FOR PB5069	2
I31C125BSF/RBZ	5/16-18 X 11/4 HEX WASH HEAD B	14
I31CNCF/RBZ	5/16-18 CLASS G FLANGE LOCK	14



Figure 1

STEP 2

- A. Measure the suspension travel. This measurement is used to determine the distance between the fender and the wheel.
 - a. For air suspension systems, let the air out of the air bags.
 - b. For spring systems, measure from the stops on the springs to the bottom of the frame.

NOTE: For air suspensions with travel exceeding 6":

In some cases a travel stop may need to be installed to prevent such large gaps between the fenders & tires. This will help with alignment and 5th wheel plate clearance. (Please call Minimizer @ 800-248-3855 for questions regarding this issue).

- B. Gap the fenders $\frac{3}{4}$ " over the maximum travel point of the suspension system. The goal is to make sure the fender does not rub on the tire. A gap larger than $\frac{3}{4}$ " may be necessary if using worn tires.

TIP: Establish the $\frac{3}{4}$ " minimum gap required in Step 2B.

- a. For an air suspension system, place a $\frac{3}{4}$ " board on top of the tires after the air has been let out of the airbags (Figure 2). Place the fender on top of the board.
- b. For a spring suspension system, add $\frac{3}{4}$ " to the measurement from Step 2A.

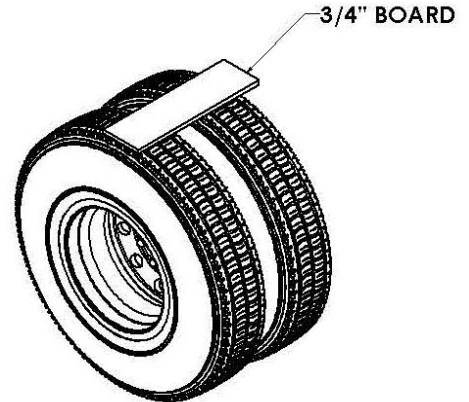

Figure 2

STEP 3

- A. Position the fenders exactly where they will be mounted.
 - a. Visually pick and mark the locations that the brackets will bolt to the frame.
- B. Try to use existing holes in the frame to bolt through. It is possible to remove any existing frame bolt and replace it with the supplied bolt in the bracket kit.
 - a. Splash guards are available if additional coverage is wanted with a half fender set (Figure 3).



Figure 3

- C. Spacers are supplied to bring the steel swivel away from the frame in the event of any obstructions (Figure 4).
 - c. The ideal setup is to mount the steel swivel directly to the frame.

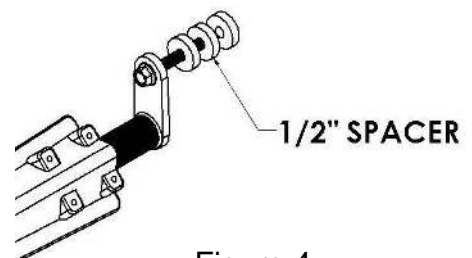

Figure 4

NOTE: Use spacers only when necessary.

D. Install center bracket assembly (Figure 5).

- a. Try to use existing holes in the frame to bolt through. It is possible to remove any existing frame bolt and replace it with the supplied bolt in the bracket kit.

Recommended torque for the 5/8 x 2-1/2" bolt with washer is 110-115 ft-lbs

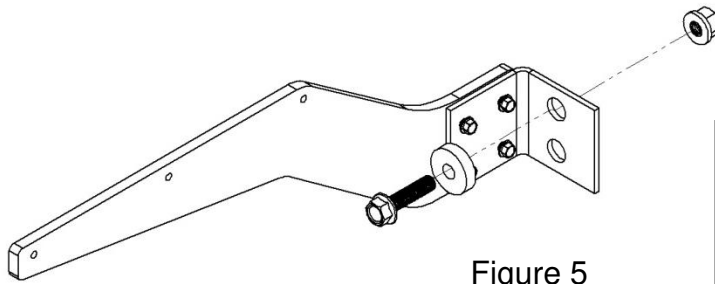

Figure 5

See IMPORTANT assembly instructions for center bracket PB5069 & PB5067, last page of this form.

E. Install center bracket as close to the end of the fender as possible (Figure 6).

- a. Drill three 5/16" holes through the fender using the holes in bracket PB5069 as a guide.
- b. Use three 5/16" x 1 1/4" bolts to bolt the center bracket and fender together. **Recommended torque for all 5/16" hardware is 10-15 ft-lbs.**
- c. Use 5/16" body washers and 5/16" nuts provided with the kit on the inside of the fender.

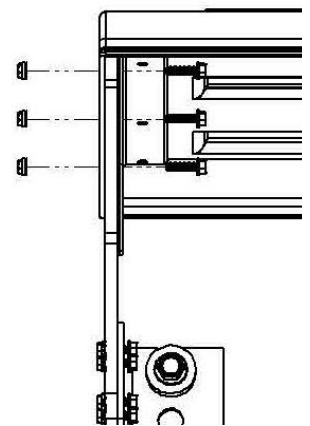

Figure 6

F. Some installations may not allow the center bracket to bolt through the end of the fender.

- a. In these cases use the plastic angle (PB5071) to connect the fender to the center bracket assembly (Figure 7).
- b. Use three 5/16" x 1" bolts, washers, and nuts to bolt PB5071 to the center bracket assembly. Do not tighten until these until the fender is level. **Recommended torque is 10-15 ft-lbs.**

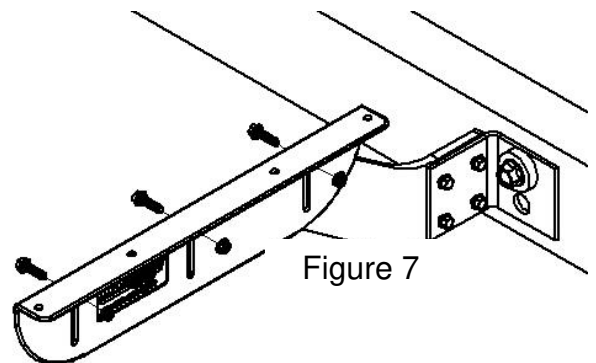

Figure 7

Tip: PB5071 is also used as a height adjustment for the end of the fender.

G. Drill four 5/16" holes through the fender using the holes in bracket PB5071 as a guide (Figure 8).

- a. Install the 5/16" x 1 1/4" bolts through the bracket and into the fender.

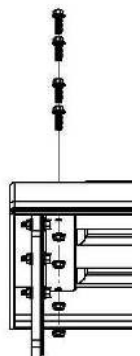

Figure 8

- b. Use 5/16" fender washers and 5/16" nuts provided with the kit on the underside of the fender. Torque all 5/16" bolts to 10-15 ft-lbs.

- H. If possible, position the mounting brackets so they are located within 15" of the bottom of the fender. This protects against wind blowing the leading edge of the fender back into the tire (Figure 9).

Tip If the front fender bracket is mounted higher than 15", refer to <http://www.minimizer.com/instructions.html> for further suggestions on adding additional support.

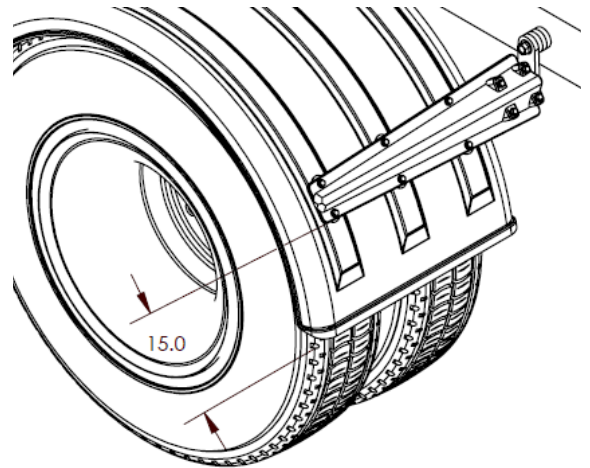

Figure 9

STEP 4

- A. Use four 5/16" x 3" bolts to attach the bracket (part number PB501026) and the backing block (part number PBLOCK) to the steel swivel (part number PB5015). As shown in Figure 10. **Make sure the pipe end of the PB5015 is fully engaged into the bracket.**

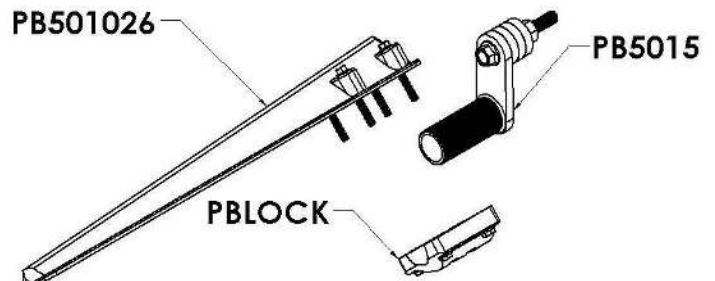

Figure 10

TIP: USE CARE WITH POWER TOOLS AS OVER-TORQUING WILL CAUSE CRACKS IN THE BRACKET. RECOMMENDED TORQUE IS 10-15 ft-lbs.

NOTE: DO NOT EXCEED RECOMMENDED TORQUE. THIS WILL VOID THE WARRANTY.

TIP: Do not completely tighten one side of the backing block before moving to the other side. Alternate tightening bolts as pictured in Figure 11. Make sure to only tighten halfway and then repeat the pattern in Figure 11 until backing block is tight.

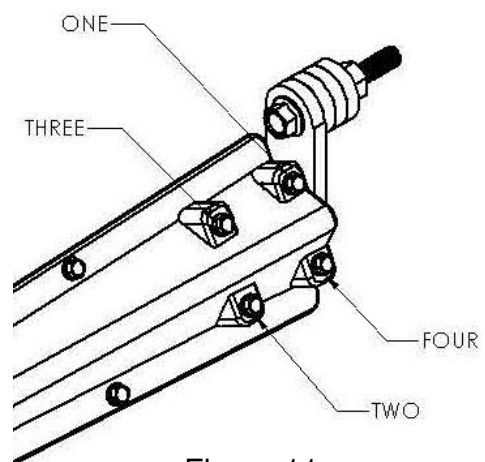

Figure 11

STEP 5

- A. Once the brackets are placed in position with the fender, securely tighten the 5/8" x 4-1/2" bolts that go through the PB5015 steel swivel to attach the swivel securely to the frame (Figure 12). **Recommended torque is 160-170 ft-lbs.**

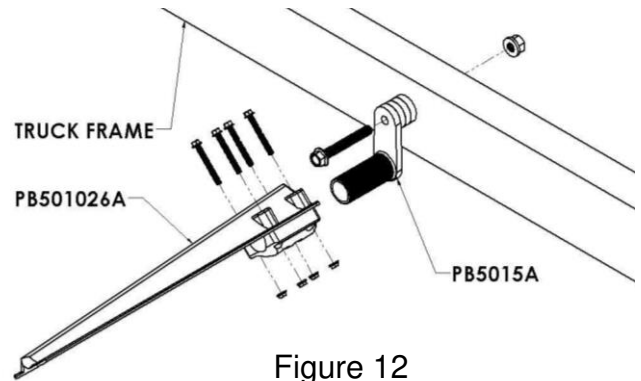

Figure 12

STEP 6

- A. Attach the bracket (PB501026A) to the fender.
- Drill six 5/16" holes through the fender using the holes in bracket PB501026A as a guide.
 - Install the 5/16" x 1" bolts through the bracket and into the fender.
 - Use six 5/16" body washers and 5/16" nuts provided with the kit on the underside of the fender.
 - Tighten the bolts to recommended torque of 10-15 FT-LBS.** Hand tightening with Torque wrench is recommended. **DO NOT EXCEED RECOMMENDED TORQUE.**
 - Make sure the fenders are square and aligned (Figure 13). Twists or bows in the fender will fatigue the material over time.

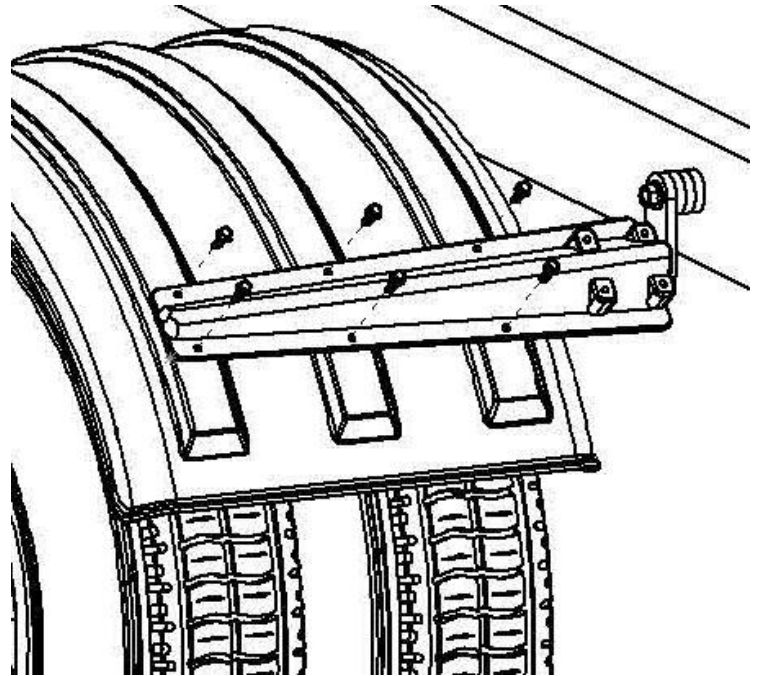

Figure 13

STEP 7

- A. For trucks with air suspension, raise and lower the suspension one final time to confirm that there is adequate clearance between the fenders and wheels.
- B. Recheck all brackets and bolts to ensure they are tightened to the recommended torque.

NOTE: ONCE FENDERS ARE IN SERVICE OCCASIONALLY CHECK TORQUE ON 5/8" X 4-1/2" HEX BOLTS IN THE FRAME TO MAKE SURE THEY DO NOT LOOSEN OVER TIME.

ZONE	REV.	DESCRIPTION	DATE	APPROVED
------	------	-------------	------	----------

IMPORTANT INFORMATION

Assemble a left hand and right hand arm assembly as shown. The bolt head (MUST) be on the metal plate side. The serration on the bottom of the bolt head will damage the plastic arm. Use the nut on the plastic arm side. Tighten from the bolt head side so the nut does not spin on the plastic arm. If the locknut is ever loosened after it has been tightened it is highly recommended to replace the locknut.

RECOMMENDED TORQUE FOR ALL 5/16 HARDWARE IS 10-15 FT-LBS

CAUTION: OVERTIGHTENING THE HARDWARE WILL DAMAGE THE PLASTIC ARM AND COULD CAUSE IT TO FAIL.

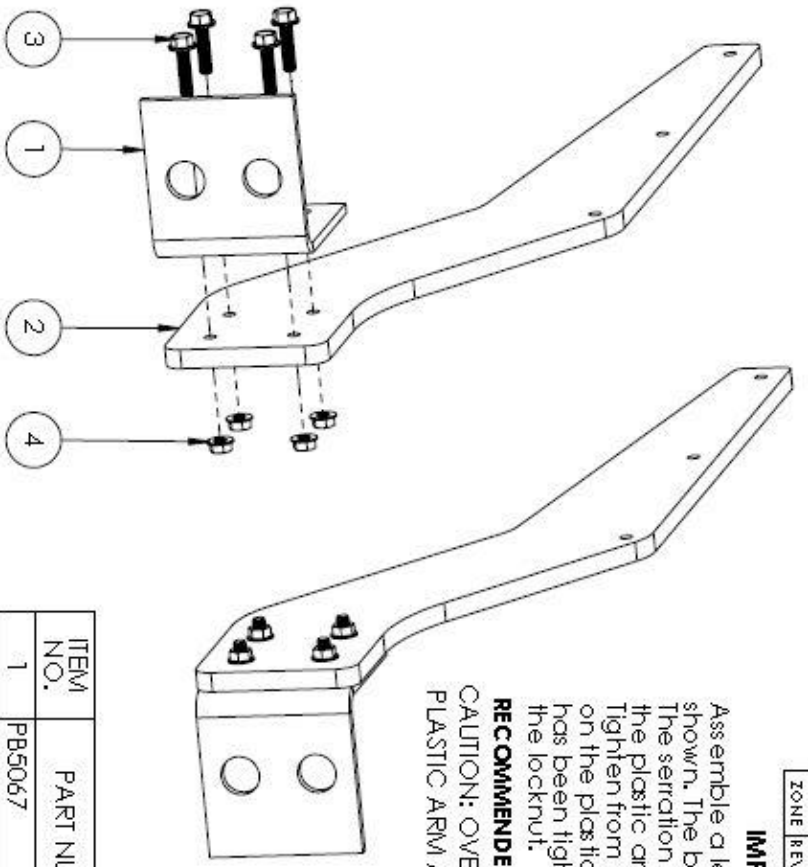

ITEM NO.	PART NUMBER	DESCRIPTION	QTY.
1	PB5067	BRKT,.5067 STL,CNTR,ANGL	2
2	PB5069	BRKT,.5069,PE,CNTR,.5	2
3	I31C125BSF/RBZ	HDWR,H.HCS.,RBZ,SERR,5/16-18X1.2	8
4	I31CNCF/RBZ	HDWR,NUT,RBZ,FLNG-LOCK,5/16-18	8

<p>UNLESS OTHERWISE SPECIFIED DIMENSIONS ARE IN INCHES TOLERANCES:</p> <p>1 FRACTION DECIMAL .13</p> <p>2 FRACTION DECIMAL .10</p> <p>3 FRACTION DECIMAL .080</p> <p>4 FRACTION DECIMAL .050</p> <p>5 FRACTION DECIMAL .030</p> <p>6 FRACTION DECIMAL .020</p> <p>7 FRACTION DECIMAL .015</p> <p>8 FRACTION DECIMAL .010</p> <p>9 FRACTION DECIMAL .008</p> <p>10 FRACTION DECIMAL .005</p> <p>11 FRACTION DECIMAL .003</p> <p>12 FRACTION DECIMAL .002</p> <p>13 FRACTION DECIMAL .001</p> <p>14 FRACTION DECIMAL .0005</p> <p>15 FRACTION DECIMAL .0003</p> <p>16 FRACTION DECIMAL .0002</p> <p>17 FRACTION DECIMAL .0001</p> <p>18 FRACTION DECIMAL .00005</p> <p>19 FRACTION DECIMAL .00003</p> <p>20 FRACTION DECIMAL .00002</p> <p>21 FRACTION DECIMAL .00001</p> <p>22 FRACTION DECIMAL .000005</p> <p>23 FRACTION DECIMAL .000003</p> <p>24 FRACTION DECIMAL .000002</p> <p>25 FRACTION DECIMAL .000001</p> <p>26 FRACTION DECIMAL .0000005</p> <p>27 FRACTION DECIMAL .0000003</p> <p>28 FRACTION DECIMAL .0000002</p> <p>29 FRACTION DECIMAL .0000001</p> <p>30 FRACTION DECIMAL .00000005</p> <p>31 FRACTION DECIMAL .00000003</p> <p>32 FRACTION DECIMAL .00000002</p> <p>33 FRACTION DECIMAL .00000001</p>	<p>DATE: 3/29/2016</p> <p>DESIGNER: TSP</p> <p>REFER TO PRINT</p> <p>DATE: 3/29/2016</p> <p>DESIGNER: TSP</p> <p>REFER TO PRINT</p> <p>DATE: 3/29/2016</p> <p>DESIGNER: TSP</p> <p>REFER TO PRINT</p>	<p>SCALE: 1:1</p> <p>WEIGHT: N/A</p> <p>SHEET 1 OF 1</p>	<p>DATE: 3/29/2016</p> <p>DESIGNER: TSP</p> <p>REFER TO PRINT</p> <p>DATE: 3/29/2016</p> <p>DESIGNER: TSP</p> <p>REFER TO PRINT</p> <p>DATE: 3/29/2016</p> <p>DESIGNER: TSP</p> <p>REFER TO PRINT</p>
---	---	--	---

INDICATED PROJECTION

SPRAY CONTROL SYSTEMS INC.
BLOOMING PRAIRIE, MIN 55917

PLSTC,CNTR,BRKT,ASSY,INSRT