



B4850WOA

Fender Mounting Instructions for MIN4050, MIN950 & MIN1550 Fenders

STEP 1

- A. Unpack all cartons and lay out parts.
- B. Compare the parts with hardware kit B4850WOA as shown in Figure 1.

| PART NUMBER | DESCRIPTION | QTY |
|-----------------|--------------------------------|-----|
| PB5010 | STEEL WELD-ON TAPERED BRACKET | 2 |
| I31C100BSF/RBZ | 5/16-18 X 1 HEX WASHER HEAD BL | 12 |
| I31CNCF/RBZ | 5/16-18 CLASS F FLANGE LOCK | 12 |
| I31N150WFEZ | 5/16 X 1 1/2 FENDER WASHER | 12 |
| PB5067 | STEEL ANGLE FOR PB5069 | 2 |
| I62C250BFL8/RBZ | 5/8-11 X 2 1/2 HEX FLG BOLT BZ | 2 |
| I62CNCG/RBZ | 5/8-11 CLASS G FLANGE LOCK N | 2 |
| PB1/2"SPACER | 1/2" POLY SPACER | 2 |
| PB5069 | COMPOSITE CENTER BRACKET | 2 |
| I31C125BSF/RBZ | 5/16-18 X 11/4 HEX WASH HEAD B | 8 |
| I31CNCF/RBZ | 5/16-18 CLASS F FLANGE LOCK | 8 |
| PB5071 | COMPOSITE ANGLE FOR PB5069 | 2 |
| I31C125BSF/RBZ | 5/16-18 X 11/4 HEX WASH HEAD B | 14 |
| I31CNCF/RBZ | 5/16-18 CLASS G FLANGE LOCK | 14 |



Figure 1

STEP 2

- A. Measure the suspension travel. This measurement is used to determine the distance between the fender and the wheel.
 - a. For air suspension systems, let the air out of the air bags.
 - b. For spring systems, measure from the stops on the springs to the bottom of the frame.

NOTE: For air suspensions with travel exceeding 6”:

In some cases a travel stop may need to be installed to prevent such large gaps between the fenders & tires. This will help with alignment and 5th wheel plate clearance. (Please call Minimizer @ 800-248-3855 for questions regarding this issue).

- B. Gap the fenders $\frac{3}{4}$ " over the maximum travel point of the suspension system. The goal is to make sure the fender does not rub on the tire. A gap larger than $\frac{3}{4}$ " may be necessary if using worn tires.

TIP: Establish the $\frac{3}{4}$ " minimum gap required in Step 2B.

- a. For an air suspension system, place a $\frac{3}{4}$ " board on top of the tires after the air has been let out of the airbags (Figure 2). Place the fender on top of the board.
- b. For a spring suspension system, add $\frac{3}{4}$ " to the measurement from Step 2A.

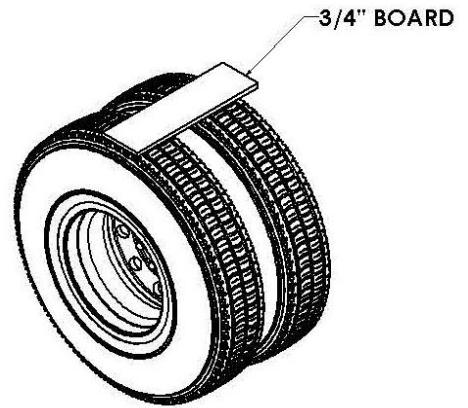

Figure 2

STEP 3

- A. Position the fenders exactly where they will be mounted.
 - a. Visually pick and mark the locations that the brackets will attach to the frame.
- B. It is possible to bolt a plate (not supplied) to the frame and weld the brackets to that plate (Figure 3). Another option is to weld the bracket directly to the frame.
 - a. Plate should be a minimum of $\frac{1}{4}$ " thick steel.

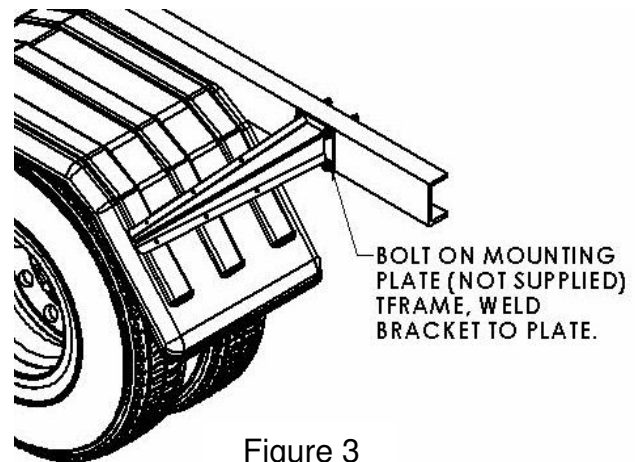

Figure 3

Tip: Check owner's manual before welding directly to the frame. Most manufacturers do not suggest welding anything directly to the frame.

- b. Splash guards are available if additional coverage is wanted with a half fender set (Figure 4).

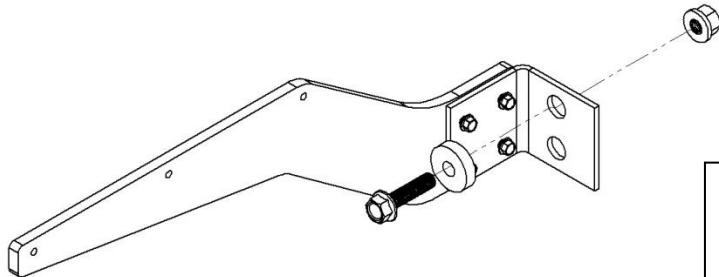

Figure 4

C. Install center bracket assembly (Figure 5).

- a. Try to use existing holes in the frame to bolt through. It is possible to remove any existing frame bolt and replace it with the supplied bolt in the bracket kit.

Recommended torque for the 5/8 x 2-1/2" bolt with washer is 110-115 ft-lbs.



See IMPORTANT assembly instructions for center bracket PB5069 & PB5067, last page of this form.

Figure 5

D. Install center bracket as close to the end of the fender as possible (Figure 6).

- a. Drill three 5/16" holes through the fender using the holes in bracket PB5069 as a guide.
- b. Use three 5/16" x 1 1/4" bolts to bolt the center bracket and fender together.
- b. Use 5/16" fender washers and 5/16" nuts provided with the kit on the inside of the fender. **Recommended torque is 10-15 ft-lbs.**

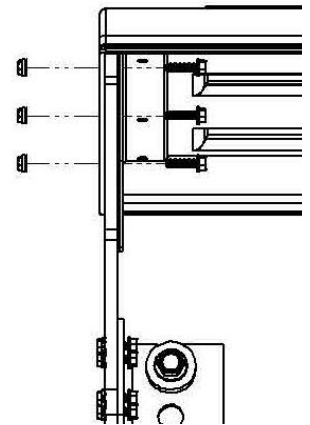

Figure 6

E. Some installations may not allow the center bracket to bolt through the end of the fender.

- a. In these cases use the plastic angle (PB5071) to connect the fender to the center bracket assembly (Figure 7).
- c. Use three 5/16" x 1" bolts, washers, and nuts to bolt PB5071 to the center bracket assembly. Do not tighten until these until the fender is level. **Recommended torque is 10-15 ft-lbs.**

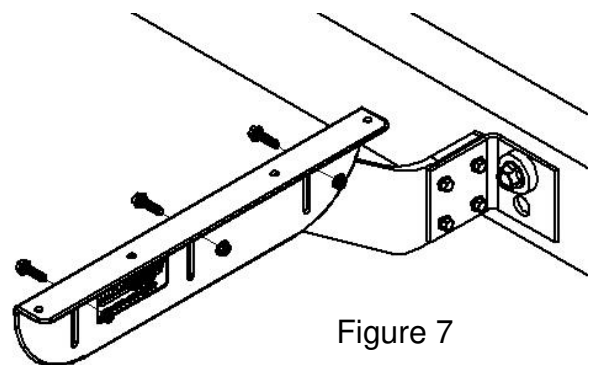

Figure 7

Tip: PB5071 is also used as a height adjustment for the end of the fender.

F. Drill four 5/16" holes through the fender using the holes in bracket PB5071 as a guide (Figure 8).

- a. Install the 5/16" x 1 ¼" bolts through the bracket and into the fender.
- d. Use 5/16" fender washers and 5/16" nuts provided with the kit on the underside of the fender. **Recommended torque is 10-15 ft-lbs.**

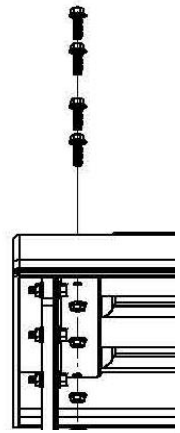

Figure 8

Step 4

If possible, position the mounting brackets so they are located within 15" of the bottom of the fender. This protects against wind blowing the leading edge of the fender back into the tire (Figure 9).

Tip: If the front fender bracket is mounted higher than 15", refer to <http://www.minimizer.com/instructions%20.html> for further suggestions on adding additional support.

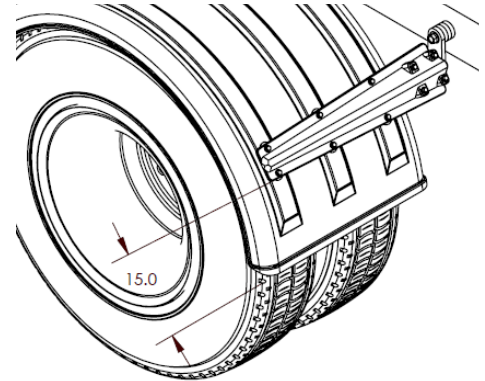

Figure 9

STEP 5

A. Attach the bracket (PB5010) to the fender.

- a. Drill six 5/16" holes through the fender using the holes in bracket PB5010 as a guide.
- b. Install the 5/16" x 1" bolts through the bracket and into the fender.
- c. Use six 5/16" fender washers and 5/16" nuts provided with the kit on the underside of the fender.
- d. **Tighten the bolts. Recommended torque is 10-15 ft-lbs.**
- e. Make sure the fenders are square and aligned (Figure 10). Twists or bows in the fender will fatigue the material over time.

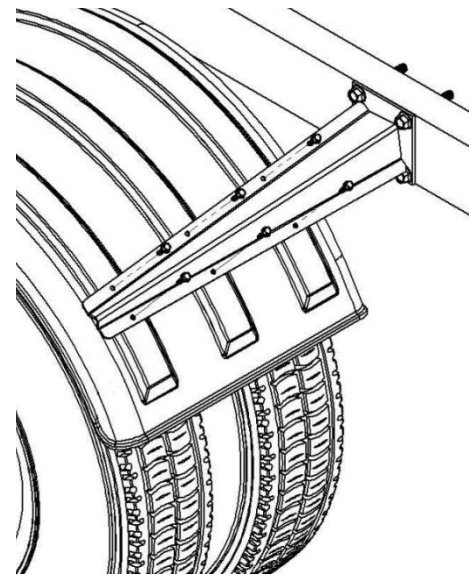

Figure 10

STEP 6

A. For trucks with air suspension, raise and lower the suspension one final time to confirm that there is adequate clearance between the fenders and wheels.

B. Recheck all brackets and bolts to ensure they are tightened to the recommended torque

| ZONE | | REV | | DESCRIPTION | DATE | APPROVED |
|------|--|-----|--|-------------|------|----------|
| | | | | | | |

IMPORTANT INFORMATION

Assemble a left hand and right hand arm assembly as shown. The bolt head (MUST) be on the metal plate side. The serration on the bottom of the bolt head will damage the plastic arm. Use the nut on the plastic arm side. Tighten from the bolt head side so the nut does not spin on the plastic arm. If the locknut is ever loosened after it has been tightened it is highly recommended to replace the locknut.

RECOMMENDED TORQUE FOR ALL 5/16 HARDWARE IS 10-15 FT-LBS
CAUTION: OVERTIGHTENING THE HARDWARE WILL DAMAGE THE PLASTIC ARM AND COULD CAUSE IT TO FAIL

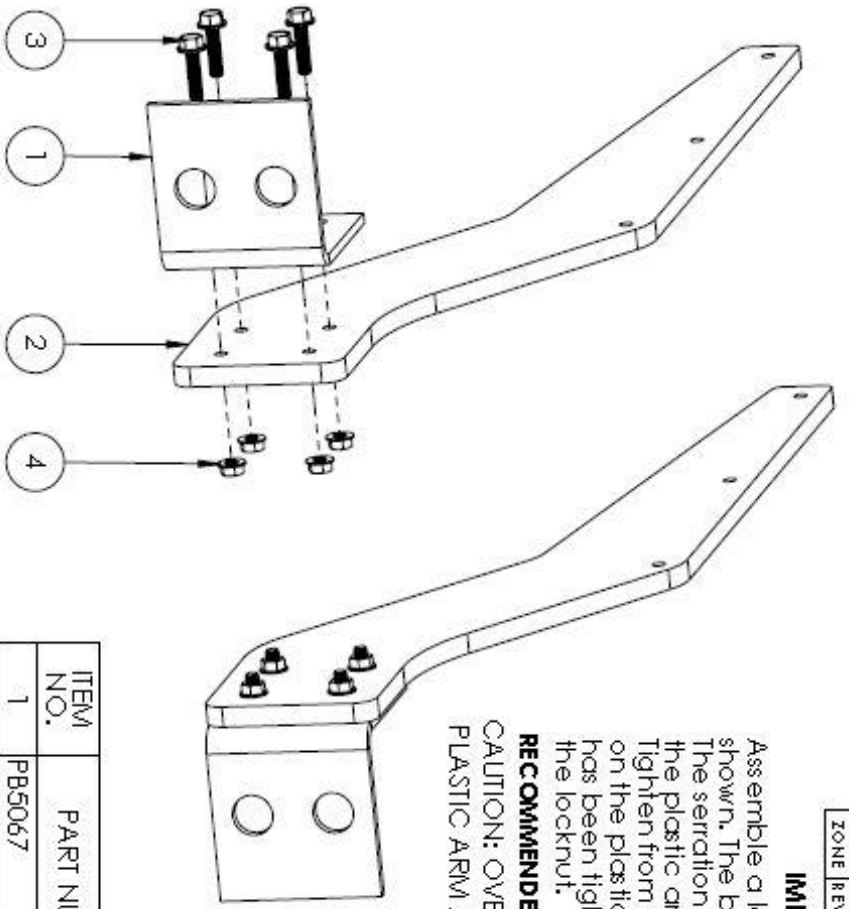

| ITEM NO. | PART NUMBER | DESCRIPTION | QTY. |
|----------|----------------|--------------------------------|------|
| 1 | PB5067 | BRKT,5067STL,CNTR,ANGL | 2 |
| 2 | PB5069 | BRKT,5069,PE,CNTR,.5 | 2 |
| 3 | I31C125BSF/RBZ | HDWR,HHCS,RBZ,SERR,5/16-18X1.2 | 8 |
| 4 | I31CNCF/RBZ | HDWR,NUT,RBZ,FLNG-LOCK,5/16-18 | 8 |

| | | |
|------------|----------------|-------------------------------|
| DESIGN BY: | MATTHEW | UNITED CHEM SERVICE SPEC PROD |
| BAG | REFER TO PRINT | DRAWING DATE IN INCHES |
| DATE: | 3/29/2016 | 1/8" = 1" (DECIMAL) |
| SCALE: | 1/4" | 1/8" = 1" (DECIMAL) |
| PROJECT: | REFER TO PRINT | 1/4" = 1" (DECIMAL) |
| DATE: | | 1/8" = 1" (DECIMAL) |
| PROJECT: | | 1/4" = 1" (DECIMAL) |
| DATE: | | 1/8" = 1" (DECIMAL) |
| PROJECT: | | 1/4" = 1" (DECIMAL) |
| DATE: | | 1/8" = 1" (DECIMAL) |

| | | | | | |
|--------|-----------|---------|---------------|--------|--------|
| SCALE: | 1/4" = 1" | NO. | B5068A-B5070A | REV: | |
| SCALE: | 1/4" | WEIGHT: | N/A | SHEET: | 1 OF 1 |

SPRAY CONTROL SYSTEMS INC.

BLOOMING PRAIRIE, MN 55917
 PLSTC, CNTR, BRKT, ASSY, INSRT

UNLESS OTHERWISE SPECIFIED
 DIMENSIONS ARE IN INCHES
 TOLERANCES:
 FRACTIONS DECIMALS
 ONE PLACE DECIMAL ±.015
 TWO PLACE DECIMAL ±.010
 THREE PLACE DECIMAL ±.005
 ANGULAR TOLERANCE:
 ONE PLACE DECIMAL ±.5°
 TWO PLACE DECIMAL ±.2°

REVISIONS ARE CONTROLLED BY THE
 REVISIONS ARE CONTROLLED BY THE
 REVISIONS ARE CONTROLLED BY THE
 REVISIONS ARE CONTROLLED BY THE
 REVISIONS ARE CONTROLLED BY THE

INTRODUCE PROTECTION