



## B4850PBA

### Fender Mounting Instructions for MIN4050, MIN950 & MIN1550 Fenders

#### STEP 1

- A. Unpack all cartons and lay out parts.
- B. Compare the parts with hardware kit B4850PBA as shown in Figure 1.

PART NUMBER	DESCRIPTION	QTY
PB5019	5.75" SWIVEL BRACKET	2
I62C450BFL8/RBZFT	5/8-11 X 4 1/2 HEX FLANGE BOLT	2
I62CNCG/RBZ	5/8-11 CLASS G FLANGE LOCK N	2
PB1/2"SPACER	1/2" POLY SPACER	6
PB5030	26" PADDLE BRACKET	2
PB5054	PADDLE BKT CLMP 2 1/4 ACCUSEAL	2
I31C62BSF/NPAT	5/16-18X5/8 SERR FLANGE BOLT Z	12
I31N125WFEZ	5/16X1 1/4 FENDER WASHER Z	12
PB5067	STEEL ANGLE FOR PB5069	2
I62C250BFL8/RBZ	5/8-11 X 2 1/2 HEX FLG BOLT BZ	2
I62CNCG/RBZ	5/8-11 CLASS G FLANGE LOCK N	2
PB1/2"SPACER	1/2" POLY SPACER	2
PB5069	COMPOSITE CENTER BRACKET	2
I31C125BSF/RBZ	5/16-18 X 11/4 HEX WASH HEAD B	8
I31CNCF/RBZ	5/16-18 CLASS F FLANGE LOCK	8
PB5071	COMPOSITE ANGLE FOR PB5069	2
I31C125BSF/RBZ	5/16-18 X 11/4 HEX WASH HEAD B	14
I31CNCF/RBZ	5/16-18 CLASS F FLANGE LOCK	14



Figure 1

#### STEP 2

- A. Measure the suspension travel. This measurement is used to determine the distance between the fender and the wheel.
  - a. For air suspension systems, let the air out of the air bags.
  - b. For spring systems, measure from the stops on the springs to the bottom of the frame.

**NOTE: For air suspensions with travel exceeding 6":**

In some cases a travel stop may need to be installed to prevent such large gaps between the fenders & tires. This will help with alignment and 5<sup>th</sup> wheel plate clearance. (Please call Minimizer @ 800-248-3855 for questions regarding this issue).

- B. Gap the fenders  $\frac{3}{4}$ " over the maximum travel point of the suspension system. The goal is to make sure the fender does not rub on the tire. A gap larger than  $\frac{3}{4}$ " may be necessary if using worn tires.

**TIP:** Establish the  $\frac{3}{4}$ " minimum gap required in Step 2B.

- a. For an air suspension system, place a  $\frac{3}{4}$ " board on top of the tires after the air has been let out of the airbags (Figure 2). Place the fender on top of the board.
- b. For a spring suspension system, add  $\frac{3}{4}$ " to the measurement from Step 2A.

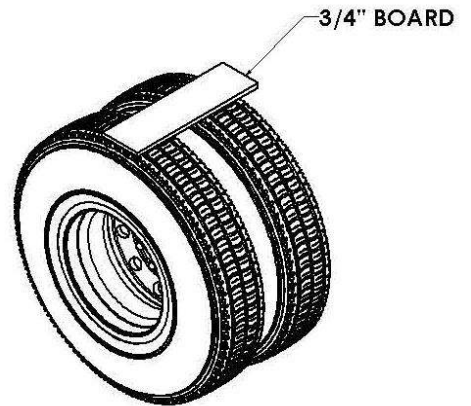

Figure 2

### **STEP 3**

- A. Position the fenders over the tires exactly where they will be mounted.
- B. Insert the PB5030 Paddle Bracket onto a PB5019 swivel bracket as shown in Figure 3.
- C. Hold the bracket assembly over top of the fenders and against the truck frame to visually mark the locations where the brackets will bolt to the frame.

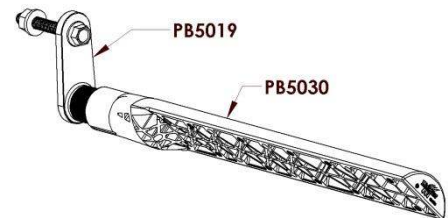

Figure 3

- a. Try to use existing holes in the frame to attach the PB5019. It is possible to remove any existing frame bolt and replace it with the supplied bolt in the bracket kit.
- b. Splash guards are available for additional coverage is wanted with a half fender set (Figure 4).

**Tip:** It is common for the front bracket to align with the existing quarter fender holes.



Figure 4

- c. Where possible it is best to bolt the steel swivel bracket directly to the frame as shown in Figure 5. There are two mounting holes in the swivel bracket to choose from. If using the mounting hole inside the pipe as shown in Figure 5 the excess flat steel may be trimmed off to provide a cleaner look.
- d. For situations where frame components are in the way of the PB5019 swivel bracket, trim off the pipe component of the swivel bracket and substitute a round spacer to gain clearance around the obstruction.



Figure 5

- i. If spacers are required, determine the minimum number of spacers needed to clear the obstruction.
- ii. Trim off the pipe of the PB5019 to provide room for the spacers. There are three lines cut in to the pipe to act as a guide. See Figure 6 for a detailed view.

**NOTE: Use spacers only when necessary.**

Trim PB5019 on the appropriate guide line when using 1, 2, or 3 spacers.

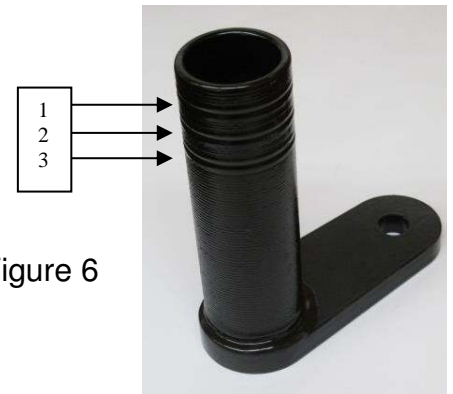

Figure 6

- D. If possible, position the mounting brackets so they are located within 15" of the bottom of the fender. This guards against wind blowing the leading edge of the fender back into the tire (Figure 7).

**Tip:** If the front fender bracket is mounted higher than 15", refer to: <http://www.minimizer.com/instructions.html> for further suggestions on adding additional support.

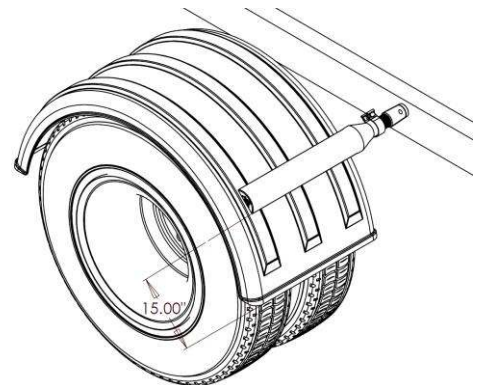

Figure 7

## STEP 4

A. Bolt the remaining PB5019 swivel brackets to the truck frame as shown in Figure 8 and tighten the nut so the brackets suit the desired position of the fender. **Recommended torque for the 5/8" X 4-1/2" bolts is 160-170 ft-lbs.**

B. Slide the PB5030 brackets onto the PB5019 swivel brackets that are mounted to the frame.

a. **Make sure the base end of the PB5030 is fully engaged into the PB5019.**

C. Rotate the PB5030 so it makes good contact with the fender.

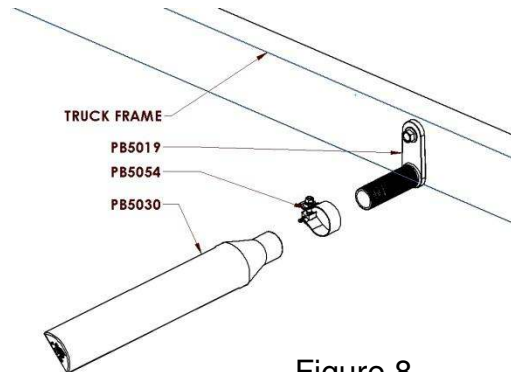

Figure 8

**NOTE: ONCE FENDERS ARE IN SERVICE, OCCASIONALLY CHECK TORQUE ON THE 5/8" X 4-1/2" HEX BOLTS IN THE FRAME TO MAKE SURE THEY DO NOT LOOSEN OVER TIME.**

## STEP 5

A. Install center bracket assembly (Figure 9).

a. Try to use existing holes in the frame to bolt through. It is possible to remove any existing frame bolt and replace it with the supplied bolt in the bracket kit. **Recommended torque for the 5/8 x 2-1/2" bolt with washer is 110-115 ft-lbs.**

See IMPORTANT assembly instructions for center bracket PB5069 & PB5067, last page of this form.

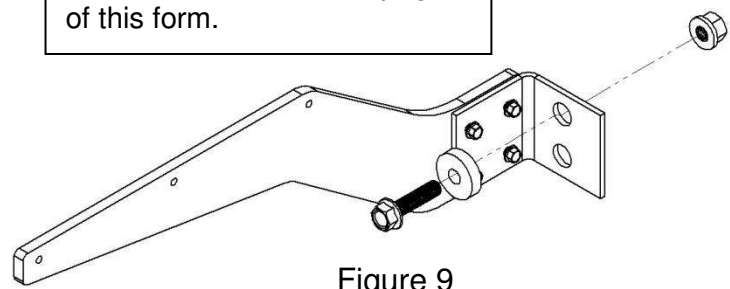

Figure 9

B. Install center bracket as close to where the fenders join together as possible (Figure 10).

a. Drill three 5/16" holes through the fenders using the holes in bracket PB5069 as a guide.

a. Use three 5/16" x 1 1/4" bolts to bolt the center bracket and fenders together. **Recommended torque for all 5/16" hardware is 10-15 ft-lbs.**

b. Use 5/16" fender washers and 5/16" nuts provided with the kit on the inside of the fenders.

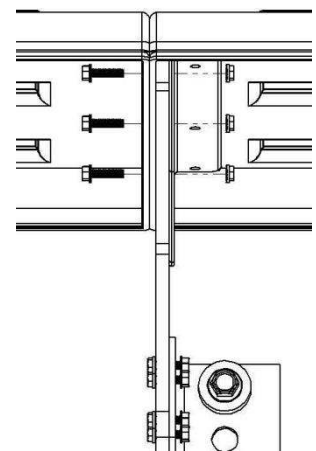

Figure 10

C. Some installations may not allow the center bracket to bolt through the ends of the fenders.

- a. In these cases use the plastic angle (PB5071) to connect the fenders to the center bracket assembly (Figure 11).
- b. Use three 5/16" x 1" bolts, washers, and nuts to bolt PB5071 to the center bracket assembly. Do not tighten these until the fender assembly is level. **Recommended torque is 10-15 ft-lbs.**

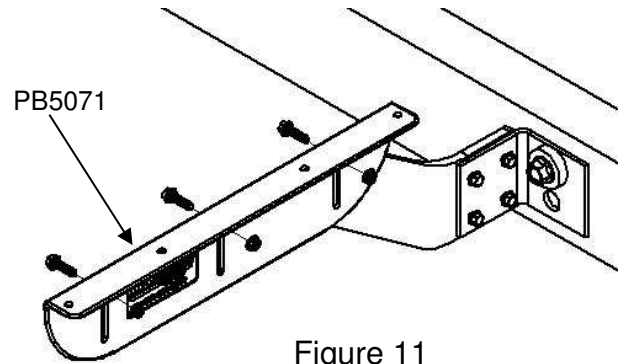

Figure 11

**Tip:** PB5071 is also used as a height adjustment for the fender assembly.

D. Drill four 5/16" holes through the fender using the holes in bracket PB5071 as a guide (Figure 12).

- a. Install the 5/16" x 1 1/4" bolts through the bracket and into the fender.
- b. Use 5/16" fender washers and 5/16" nuts provided with the kit on the underside of the fender.
- c. **Recommended torque for all 5/16" bolts is 10-15 ft-lbs.**

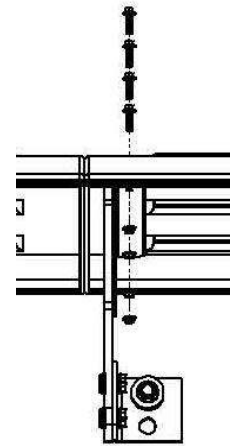

Figure 12

## **STEP 6**

A. Attach drilling template.

- a. Unpack the provided paper drilling templates that match the PB5030 bracket as shown in Figure 13.
- b. Insert the drilling template between the fender and PB5030 bracket as shown in Figure 14 and align it with the edges of the bracket.



Figure 13

- c. Verify that the fenders are resting square and aligned over the tire. Twists or bows in the fender will fatigue the material over time.
- d. Apply tape to the tabs of the template and secure the tape to the ribs of the fender as shown in Figure 15.



Figure 14

- d. Remove the fender from the wheels and confirm that all templates are secure.



Figure 15

C. Drill Mounting Holes for PB5030.

- a. Drill six 3/8" holes through the fender. Use the paper template as a guide at the locations circled below in Figure 16. One template is provided for every PB5030 bracket.

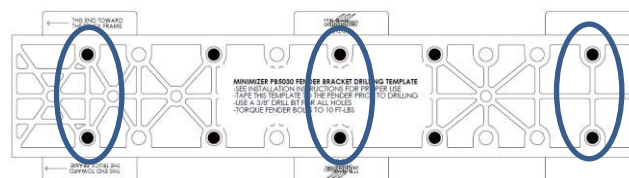

Figure 16

**STEP 7**

A. Attach the PB5030 bracket to the fender.

- a. With the bracket separated from the truck, install six 5/16" x 5/8" bolts and fender washers through the fender and into the bracket. **Turn each bolt approximately 2 full turns. Do not fully tighten.** See Figure 17 below.

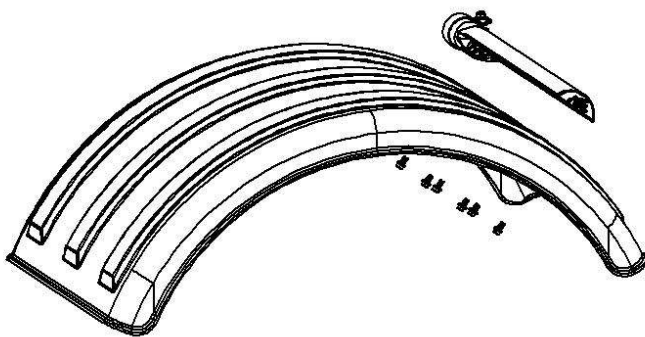

Figure 17

## **STEP 8**

- A. Attach the fender and PB5030 to the PB5019 swivel.
  - a. Carefully lift the fender & bracket assembly with PB5054 tube clamp over the tire and slide the PB5030 brackets on to the PB5019 swivel brackets mounted on the frame.
  - b. Position the PB5054 tube clamp 1/4" inside the edge of the paddle bracket as shown in Figure 18.
  - c. **Torque the tube clamp to 50 ft-lbs** using a 15mm wrench or deep well socket.
  - d. Figure 19 is a close up view of a properly torqued PB5054 tube clamp.

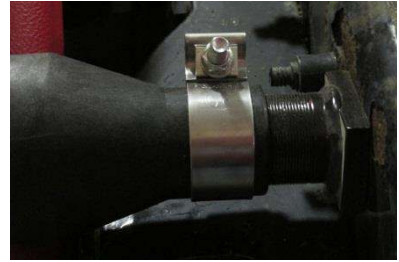

Figure 18



Figure 19

## **STEP 9**

- A. **Tighten all 5/16" x 5/8" fender bolts to 10 ft-lbs. Air tools and impact drivers are not recommended.**

## **STEP 10**

- A. For trucks with air suspension raise and lower the suspension one final time to confirm that there is adequate clearance between the fenders and wheels

**NOTE: ONCE FENDERS ARE IN SERVICE OCCASIONALLY CHECK TORQUE ON 5/8" X 4-1/2" HEX BOLTS IN THE FRAME TO MAKE SURE THEY DO NOT LOOSEN OVER TIME.**

