

# IMPORTANT SAFETY INFORMATION

Item # 105545  
September 2021

## READ BEFORE INSTALLING OR USING MINIMIZER FLOOR MATS

---

Floor Mat Kit #103738 is compatible with the following Freightliner models equipped with a manual transmission:

- Freightliner Cascadia 126 – 2018-2022
- Freightliner Cascadia 116 – 2018-2022
- Western Star 49X – 2021-2022

Floor Mat Kit #103739 is compatible with the following Freightliner models equipped with an automatic or automated manual transmission:

- Freightliner Cascadia 126 – 2018-2022
- Freightliner Cascadia 116 – 2018-2022
- Western Star 49X – 2021-2022

### Installation Notes:

- Driver, passenger, and center floor mats are designed to fit the most common OEM seat bases.  
In some cases hand trimming along raised ribs is required
  - Hand trimming of the passenger mat and center mat is required when installing in trucks equipped with battery box passenger seat.
  - Floor mat kits are compatible both with day cab and sleeper cab configurations.
- 

### SAFETY INSTRUCTIONS FOR INSTALLATION:

- Use only with the specified vehicle make, model and year.
- Do not install on top of other floor mats.
- Install each floor mat with the Minimizer logo facing up.
- Use each floor mat only in its proper location in the vehicle.
- Install and use a retention hook for the driver side floor mat.
- Make sure that the floor mats fit properly in your vehicle floor space.
- Do not place additional floor mats on top of the Minimizer floor mats.
- Carefully follow each of the Installation Instructions for Minimizer Floor Mats on the following pages.

### SAFETY INSTRUCTIONS FOR VEHICLE OPERATION:

- Before starting or operating the vehicle, verify that the Minimizer floor mats are installed correctly, that the driver side mat is secured by a retention hook, and that the driver side mat does not interfere with the accelerator, brake, or clutch pedal.
- Make sure there are no loose objects in the vehicle that could possibly interfere with the operation of the accelerator, brake, or clutch pedal.
- If your Minimizer floor mat becomes loose, stop the vehicle at the next safe location. Re-install the floor mat properly and securely. If that is not possible, remove the floor mat and place it in a location where it will not interfere with safe operation of the vehicle.
- Inform all drivers of these warnings before allowing them to operate a vehicle equipped with Minimizer floor mats.

Minimizer floor mats are specifically designed for certain vehicles and may be used safely only with those vehicles. **VERIFY THAT THE MAKE, MODEL, AND YEAR OF THE VEHICLE IN WHICH YOU ARE INSTALLING THE FLOOR MATS ARE IDENTIFIED BELOW AS BEING COMPATIBLE WITH THE MINIMIZER FLOOR MATS YOU HAVE SELECTED.**

If you have questions about these instructions or proper installation of your Minimizer floor mats, please contact Minimizer at (800) 248-3855

### WARRANTY:

Minimizer Floor Mats are backed by a Lifetime Manufacturer's Warranty and are guaranteed against flaws due to faulty materials and/or unintended production variations. This warranty extends only to the original purchaser and excludes damage caused by abnormal use or conditions, including but not limited to extreme abrasive conditions and/or excessive exposure to chemicals such as bleach, gasoline and other fuels.

Disclaimer: Minimizer custom molded floor mats are not Freightliner, Western Star, and Sterling goods and FREIGHTLINER, WESTERN STAR, and STERLING are federally registered marks of Daimler Trucks North America.

Minimizer floor mats are specifically designed for certain vehicles and may be used safely only with those vehicles. **VERIFY THAT THE MAKE, MODEL, AND YEAR OF THE VEHICLE IN WHICH YOU ARE INSTALLING THE FLOOR MATS IS IDENTIFIED ON PAGE 1 AS BEING COMPATIBLE WITH THE MINIMIZER FLOOR MATS YOU HAVE SELECTED.**

### **FREIGHTLINER FLOOR MAT KIT SPECIFICATIONS:**

- Contents of floor mat kit 103738 are shown below in Figure 1.

**Figure 1 - Kit 103738 Contents**



- Contents of floor mat kit # 103739 are shown below in Figure 2.

**Figure 2 - Kit 103739 Contents**



### **INSTALLATION INSTRUCTIONS:**

1. Remove other floor mats from the vehicle before installing Minimizer floor mats.
2. Install the Minimizer floor mats right side up, with the Minimizer logo visible.
3. Each Minimizer floor mat is contoured to fit a particular location in the vehicle and may be used safely only in that location.
4. The Minimizer floor mat package contains one driver mat, one passenger mat and one center mat.
5. Test fit the center mat in between the seats of the truck. For some cab configurations hand trimming of the center mat is required. Figure 3 shows a diagram of the center mat with provisions for trimming.

To trim the floor mat material, use a sharp utility knife. Use the raised ribbed areas shaded in yellow as a knife guide and preserve the raised rib for liquid containment.

**Figure 3 - Center Mat Trimming Diagram**

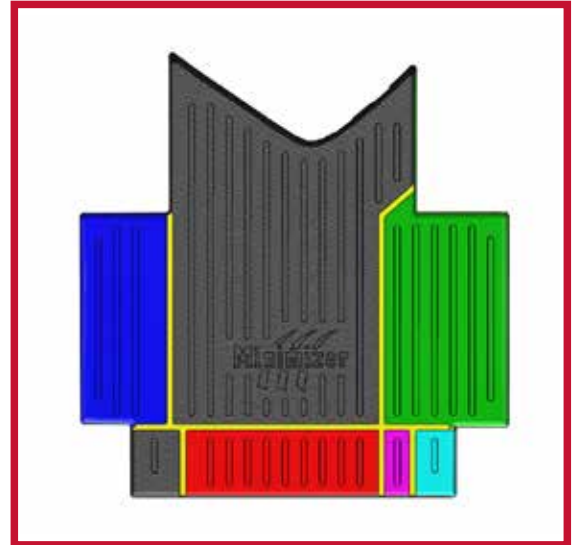

- Trucks that are equipped with a battery box passenger seat (as shown in Figure 4) will require trimming of the center and passenger floor mats. Trim off the green, purple and light blue shaded areas of the center mat shown in Figure 3 for proper fit with the battery box passenger seat.

**Figure 4 - Battery Box Passenger Seat**



**Figure 5 - Center Mat Trimming for Battery Box**



- Day cab trucks are sometimes equipped with an optional plastic storage bin that is attached to the rear wall of the cab. For trucks equipped with the storage bin, trim off the red and purple shaded areas shown in Figure 3.

- In day cab trucks it is common for the fire extinguisher or roadside safety kit to be mounted to the floor in between the driver and passenger seats. To accommodate the fire extinguisher or roadside safety kit, (if present) the center mat is designed so a portion of left side may be trimmed off. This portion is shaded dark blue in Figure 3.

6. Test fit the driver mat in the truck. The driver mat is designed to fit underneath the throttle pedal. To install the driver mat, lift up the heel portion of the throttle pedal and slide the front of the floor mat underneath the pedal. Confirm that the mat is pushed all the way forward so it rests against the fire wall.

7. Inside the package with the installation instructions, locate two black plastic retention hooks along with a white tube of Primer 94 as shown in Figure 6.

**Figure 6 - Retention Hook and Primer 94**



8. Insert one hook through the hole at the right edge of the driver mat. The hook should fit flush with the underside of the driver mat.

9. Once the hook is in place, let the driver mat and hook rest on the truck floor.

10. Mark the approximate position where the hook will be attached to the floor. Once the position is located, remove the driver mat from the truck.

11. Unpack the tube of Primer 94 and read the safety precautions printed on the tube

12. Activate the tube of Primer 94 by crushing the tube at the black dot.

13. Clean all dirt or debris off the truck floor and apply Primer 94 to the floor area where the hook will be adhered.

14. Allow the Primer 94 to dry on the truck floor for five minutes.

15. Install the driver mat in the truck with the hook inserted. Next, peel away the paper backing from the hook.

16. While holding onto neck of the hook, lower the driver mat into position and stick the hook to the floor. Apply firm pressure to the hook as shown in Figure 7 for 30 seconds to ensure a proper bond to the rubber floor.

**Figure 7 - Apply Pressure to the Hook**



17. For optimal adhesion do not disturb the hook for a period of 20 minutes after installation. Figure 8 below shows the properly installed driver mat and hook.

**Figure 8 - Driver Mat Hook Installation**



18. Pull the driver mat toward the rear of the truck to confirm that the hook is fully engaged into the mat and that the hook is adhered to the floor. If the hook is not functioning properly or the mat cannot be securely installed, do not use a Minimizer floor mat on the driver side of the vehicle.

19. FAILURE TO PROPERLY INSTALL THE HOOK FOR THE DRIVER SIDE FLOOR MAT MAY ALLOW THE FLOOR MAT TO SHIFT, WHICH MAY INTERFERE WITH PROPER FUNCTIONING OF THE VEHICLE'S PEDALS, POTENTIALLY RESULTING IN LOSS OF CONTROL OF THE VEHICLE AND SERIOUS INJURY OR DEATH.

20. Move the accelerator, brake, and clutch pedals through their full range of motion to confirm there is no interference with the Minimizer floor mat.

21. Test fit the passenger floor mat in the truck. In some cases trimming of the passenger mat will be required. Figure 9 below shows a diagram of the area that is designed to be trimmed away.

Figure 9 - Passenger Mat Trimming Diagram

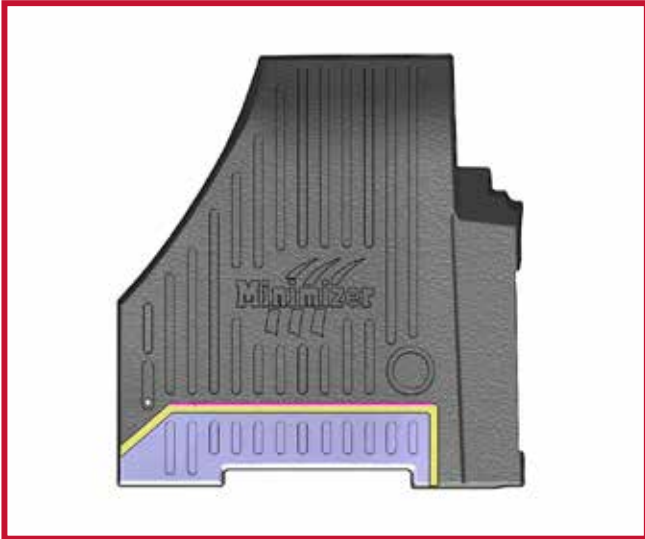

- If the truck is equipped with a battery box passenger seat, the purple shaded area of the passenger mat must be trimmed in order for the passenger mat to fit properly.

22. Install the passenger mat retention hook as shown in Figure 10. Repeat steps 9-16 above to properly attach the hook to the floor of the truck.

Figure 10 - Passenger Mat Retention Hook Location



23. Prior to operating the vehicle, read the Safety Instructions for Vehicle Operation.

24. FAILURE TO CORRECTLY INSTALL AND USE YOUR MINIMIZER FLOOR MATS ACCORDING TO THE INSTRUCTIONS ABOVE COULD PREVENT PROPER FUNCTIONING OF THE VEHICLE'S PEDALS, POTENTIALLY RESULTING IN LOSS OF CONTROL OF THE VEHICLE AND SERIOUS INJURY OR DEATH

A DIVISION OF **HIGH BAR BRANDS, LLC**



**HIGH BAR  
BRANDS**



2701 18th Street SW, Owatonna, MN 55060  
1-800-248-3855 | Fax: 507-583-7540  
[www.minimizer.com](http://www.minimizer.com)