

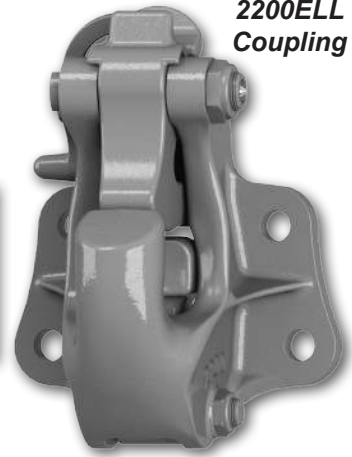

PREMIER

THE FIRST NAME IN QUALITY COUPLINGS

2200ELL
Coupling



2200PK-ELL SERVICE GUIDELINES

This guide is intended to be used to install a 2200PK-ELL kit into any 2200 series coupling

BEFORE GETTING STARTED:

- ▶ This procedure should only be performed by a qualified mechanic.
- ▶ Measure the wear on the coupling's pintle hook. If the wear is at or exceeds 20% of the cross section, the coupling is considered Out of Service. Do Not continue.
- ▶ NOTE: These instructions cover complete disassembly of any 2200 series coupling and reassembly to a 2200ELL.
- ▶ Tools required: snap ring pliers; 1 7/16" & 1 1/16" sockets; flat-bladed screw driver.
- ▶ **CAUTION:** When removing and replacing snap rings the appropriate snap ring plier tools are necessary. Do not attempt removal or replacement without the correct snap ring plier tools. In addition, use caution when removing and replacing snap rings – Do not over-expand them, as damage could result. Also, when assembling a snap ring into position - Make certain that the snap ring is fully seated into the groove.
- ▶ Safety glasses are required for all of the following procedures.
- ▶ Prior to disassembly, familiarize yourself with the location of all the various parts in the coupling. This will assist in the assembly process.
- ▶ See attached Image Reference Section(s) with photos and/or drawings to identify various product parts.
- ▶ This procedure applies to all of the model 2200 series couplings.

DISASSEMBLY

- 1) The 2200 series coupling should be positioned upright, as if mounted, with the latch in the closed position. See Image #2 in the Image Reference Section; the 2072 Latch is located at the top of the coupling.
- 2) Remove the 297 Locknut from the right side. Slide the 2071 Bolt out from the left side. Rotate the 2073 Latch Lock backwards to the open position and remove the 2072A Spring and 2072 Latch. The 2072B Bushing should be inside of the 2072 Latch bolt hole.
- 3) Locate the 388 Pin and remove the 44-62 Snap Ring from the left side. Slide the 388 Pin out from the right side and remove the 2073 Latch Lock; 2073A Spring; 2073B Bushing; and 373B Spacer. **Discard all latch component's that have been removed as they cannot be used in combination with the new 2200PK-ELL.**
- 4) **IF** you are replacing the 279 Shoe and its components, then follow instructions **below:** Otherwise, continue on to #5.
Locate the 274 Bolt and remove the 274A Locknut from the right side. Slide the 274 Bolt out from the left side and remove the 279 Shoe and 266 Spring.
- 5) With all parts removed from the coupling body, clean and inspect the body for wear and/or damage. If wear exists or damage is noted, do not attempt to repair. **DO NOT ATTEMPT WELD REPAIR OF ANY DAMAGED AND/OR WORN PART.**

DISASSEMBLY IS COMPLETE



**IMPORTANT NOTES TO CLEAN,
INSPECT & LUBRICATE:**

- ▶ Use only genuine PREMIER replacement parts on any repairs. Use of other parts, which can have different specifications or tolerances, may fail to alert you to non-obvious damage to the hitch which can lead to hitch failure.
- ▶ All body holes, part holes and pins need to be thoroughly cleaned and lubricated with a heavy grease before the parts are reassembled. **DO NOT LUBRICATE PINTLE HOOK WEAR SURFACE.**
- ▶ Clean, inspect and lubricate latch components every 90 days or sooner if required by the operating environment.
- ▶ Clean and inspect the coupling for damage and excessive wear prior to each and every use.
- ▶ Do not over-tighten fasteners as this may cause damage.

ASSEMBLY

Prior to assembly, place the 2072EL Latch into the coupling body aligning it with the upper body holes and slide the 2071EL Bolt through the holes. Rotate the latch to the closed position and measure the gap between the latch and top of the pintle. If the gap is 3/8" or more, the coupling body is damaged and must be replaced. If the gap is less than 3/8", remove the bolt, latch and bushing and begin assembly.

- 1) **IF** you are replacing the 279 Shoe and its components, then follow the instructions **below**: Otherwise continue on to #2.

Place the 266 Spring over the nipple on the 279 Shoe. Insert as assembled through the opening at the top of the coupling and into the cavity at the bottom. The 266 Spring should seat into the concave cavity, which resides below the pintle base. The 266 Spring must be slightly compressed to align the 279 Shoe hole with the bottom body hole. From the left side of the body, insert the 274 Bolt (left to right) into the bottom coupling body hole and secure on the right side with 274A

Locknut. Make certain that one of the flats of the 274 Bolt head is flush with the flat on the body sidewall. Rotate the 279 Shoe to verify proper spring tension.

- 2) Take the 2074EL Pin, with the grease zerk fitting positioned towards the right, and insert it into the right side body hole, allowing approximately 1/2" to extend past the right side interior wall surface. Place one of the 373B Spacers onto the extending end of the 2074EL Pin, within the body cavity.
- 3) Position the 2073EL Latch Lock into the body, adjacent to the 373B Spacer. Align the hole, then slide the 2074EL Pin through to the left, until flush with the left side of the 2073EL Latch Lock.
- 4) Hold the 2073A Spring so that the straight leg is pointing upward on the left side of the spring and the hooked leg is on the right. Place the spring on the left side of the 2073EL Latch Lock, aligning it with the body hole on the left side and the 2074EL Pin on the right. The straight spring leg should be along the top ledge, pointing toward you.
- 5) Rotate the 2073EL Latch Lock forward toward you and capture the hooked end of the spring with the front part of the catch ledge on the bottom of the 2073EL Latch Lock. Keeping the 2073EL Latch Lock in the forward position, push the 2074EL Pin through the 2073A Spring and out the left side of the coupling body.
- 6) Closely examine the left side's interior body sidewall, adjacent to the 2073A Spring, and locate the catch ledge running at a 45 degree angle. This is where the straight leg of the spring needs to be placed. Using a flat bladed screw driver, pry the straight leg away from the top interior ledge of the coupling and rotate it until it engages with the catch ledge. Please Note: Do not over-stress the 2073A Spring when engaging either end and also **MAKE CERTAIN** both the straight end and hooked end are completely engaged with the catch site locations (see Image #3).
- 7) Rotate the 2073EL Latch Lock backwards, to the opened position. If spring is installed correctly, smooth increasing spring resistance should be felt when rotated. If no resistance or binding is felt, the spring and/or parts are not installed correctly.



- 8) Using snap ring pliers, install one 44-62 Snap Ring into the groove on the right side of the 2074EL Pin. Verify that the snap ring is fully seated into the groove. Now slide the 2074EL pin until the 44-62 snap ring seats against the right side of the coupling body.
- 9) Insert the 2071EL Bolt from the left side into the coupling body until the threaded end is approximately 1/8" past the left side interior body sidewall. Place the 2072A Spring onto the protruding 2071EL Bolt's threaded end. The hook end of the spring should be pointing toward you and the straight leg facing downward, captured by the top interior ledge of the coupling (see Image #3).
- 10) With one hand rotate the 2073EL Latch Lock back to the opened position and hold. With the other free hand grasp the 2072EL Latch and lower into position, catching the hooked end of the spring on the left side sidewall of the 2072EL Latch. Once in position, gently allow the 2073EL Latch Lock to rotate forward, into the closed position. Now align the 2072EL Latch hole with the 2071EL Bolt and slide the bolt to the right until fully seated. Due to the snug fit, it is possible that while pushing the bolt into place, you may have to twist the bolt and wiggle the latch to get everything to line up properly. **Do not hammer or tap the bolt through. This action could possibly damage the components.** Please note there is a small indentation mark on the end of the 2071EL bolt head. This is to allow for proper orientation of the lubrication port. Prior to securing the 2071EL in position, orientate the lubrication port identifier as shown in Image #4. Now secure the bolt with the 297 Locknut on the right side while maintaining proper orientation of the 2071EL.
- 11) Rotate the 2073EL Latch Lock to the opened position and hold. Rotate the 2072EL Latch to the opened position. If the spring is installed correctly, smooth increasing spring resistance should be felt when rotated. If no resistance or binding is felt, the spring and/or parts are not installed correctly. Reassemble correctly.
- 12) Place the 373B Spacer on the left end of the 2074EL Pin that is protruding out the left side of the coupling body.
- 13) Place the 2075 Lever onto the left end of the 2074EL Pin adjacent to the 373B Spacer.
- 14) Using snap ring pliers, install one 44-62 Snap Ring into the groove on the left end of the 2074EL Pin, securing the 2075 lever and 373B bushing in position. Verify that the snap ring is fully seated into the groove.
- 15) Once the coupling is assembled it should be opened and closed several times, testing for smooth and correct operation. DO NOT use the coupling if it does not operate properly. Call for assistance.
- 16) Apply a pump or two of grease in each grease zerk fittings on the 2074EL pin and the 2071 Pin. Verify adequate greasing has occurred by checking to see if a small amount of grease came out either side of the 2073EL Latch lock and the 2072EL Latch.
- 16) Use only new fasteners torqued to SAE specifications when mounting the assembled coupling to its mounting structure.

WARNING:

Do NOT bind-up (jackknife) any application, as stresses can cause damage to the hitch, drawbar eye, other components or any combination of them. Jackknifing may result in failure of products or components, resulting in detachment of the trailer while in use.

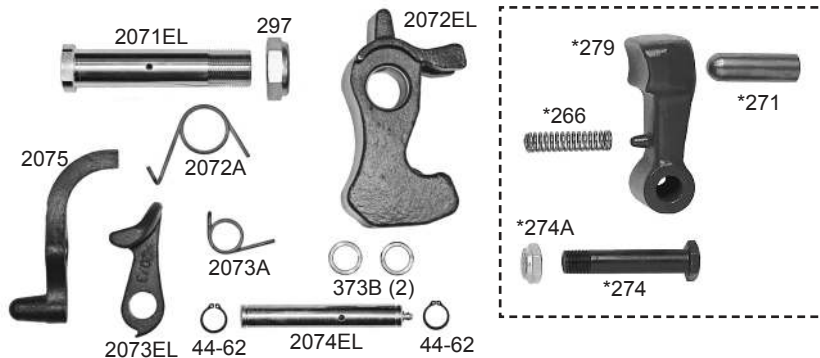

IMAGE REFERENCE SECTION

IMAGE #1

2200PK-ELL Parts Kit Includes:

- | | |
|----------------------|----------------|
| 44-62: Snap Ring (2) | *266: Spring |
| 297: Locknut | *271: Thimble |
| 373B: Spacer (2) | *274: Bolt |
| 2071EL: Bolt | *274A: Locknut |
| 2072A: Spring | *279: Shoe |
| 2072EL: Latch | |
| 2073A: Spring | |
| 2073EL: Latch Lock | |
| 2074EL: Pin | |
| 2075: Handle | |



*Not included in parts kit, available individually.

IMAGE #2

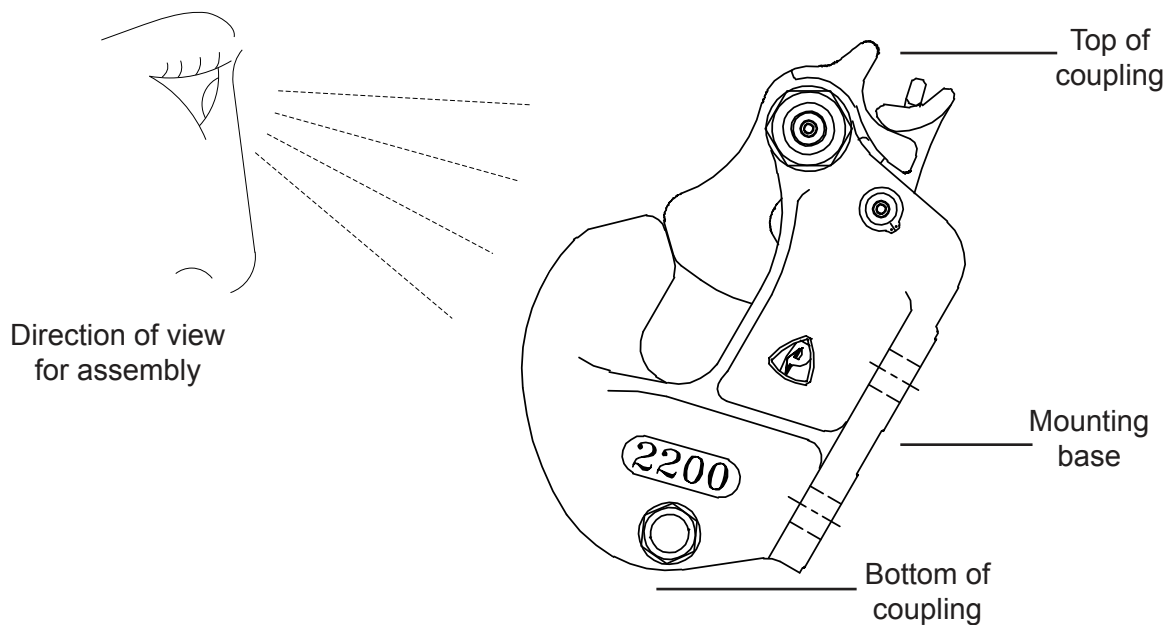

IMAGE REFERENCE SECTION

IMAGE #3

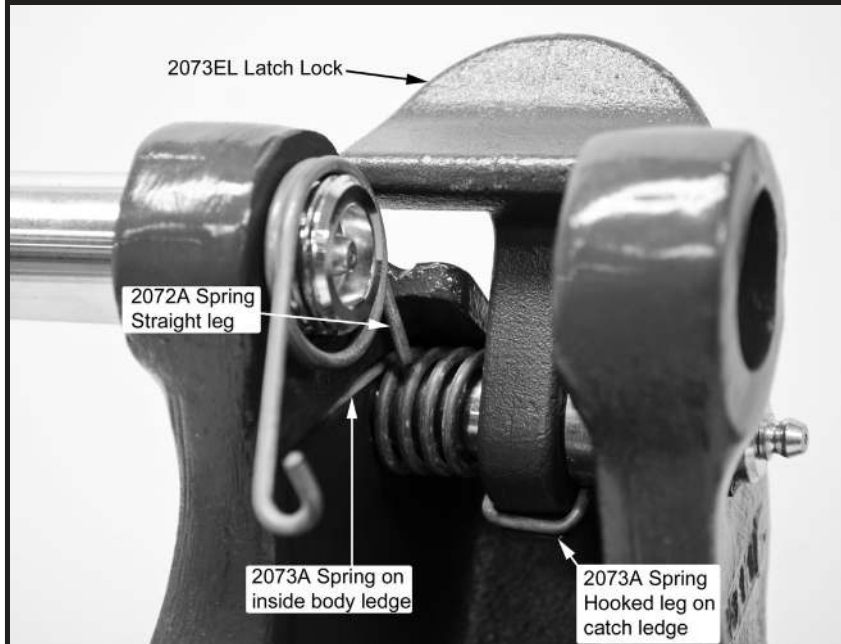

IMAGE #4

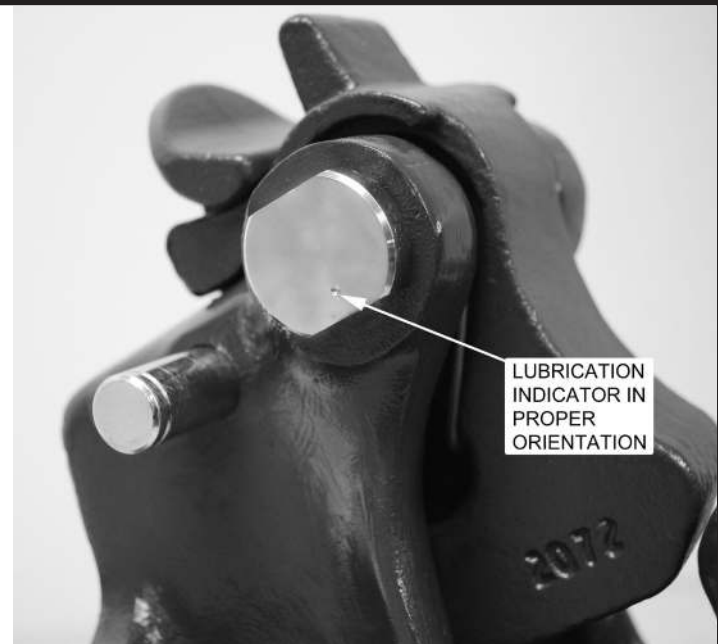
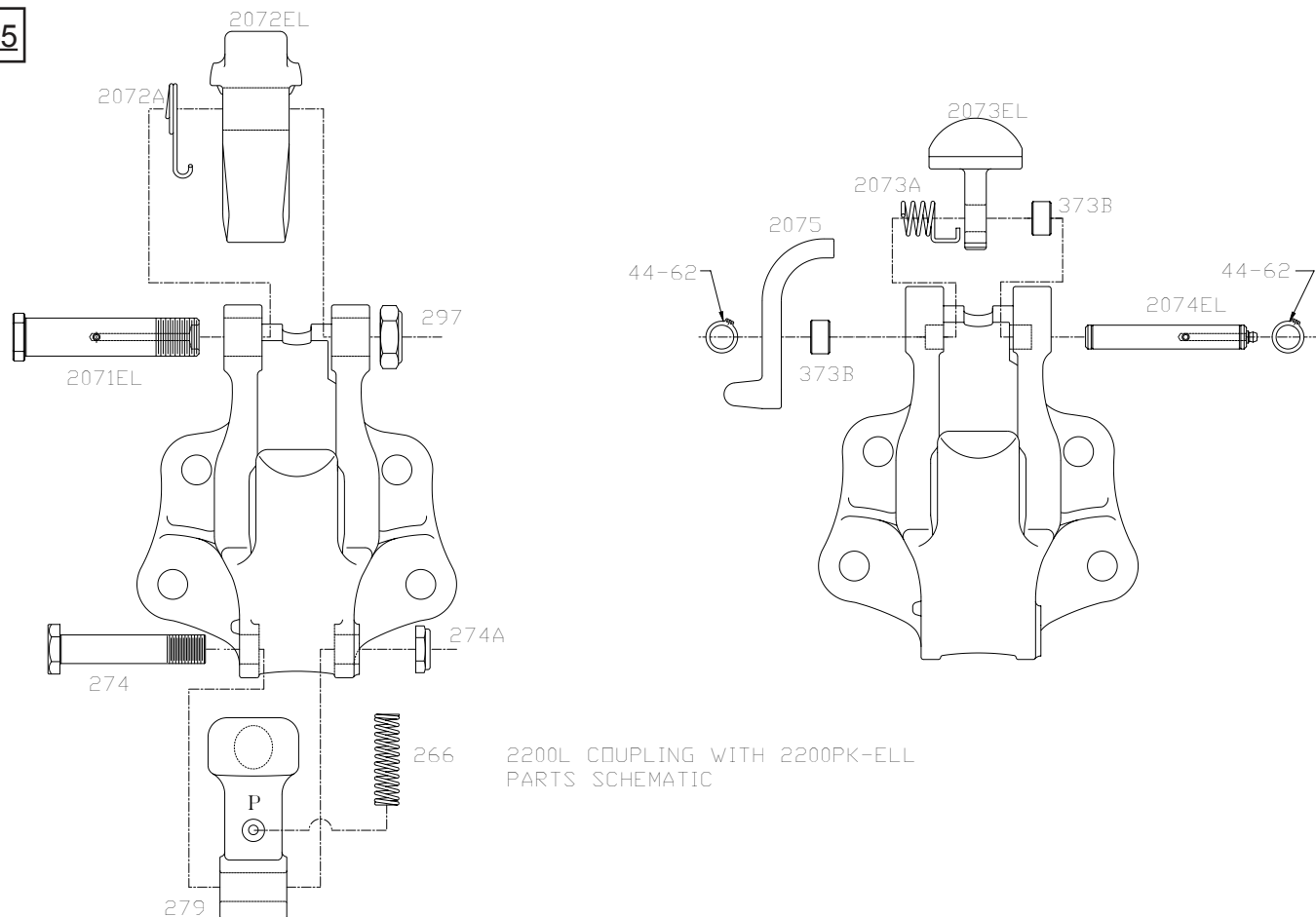

IMAGE #5



IMPORTANT GUIDELINES that apply to all Premier Air Adjusted Couplings

- Do not weld on any coupling assembly
- Always use Grade-8 fasteners properly torqued
- Do not apply lubricants to the coupling hook
- Air service chamber must be Type-24 or Type-30 with 90-120 PSI air supply
- Clean & inspect coupling for damage & excessive wear prior to each and every use
- Lubricate all coupling components at a minimum of 90 day intervals
- Do not bind-up (Jackknife) any application as stresses can cause damage to products or components, resulting in failure and detachment of the trailer while in use



CONTINUE TO NEXT PAGE FOR
IMPORTANT INFORMATION.



ATTENTION !

End Users must read and follow this information.

DISTRIBUTORS & OEM'S: Please ensure that your customers are made aware of the following information on this page.

- (1) **VERIFY THAT BOTH COUPLING'S AND DRAWBAR EYE'S RATED CAPACITIES MEET YOUR APPLICATION(S) REQUIREMENTS.**
- (2) DO NOT OVERLOAD COUPLING OR DRAWBAR EYE.
- (3) INSPECT COUPLING, LATCH AND DRAWBAR EYE FOR CRACKS, BENDING DAMAGE OR EXCESSIVE WEAR. **DO NOT USE IF ANY OF THESE CONDITIONS EXIST!**
- (4) CHECK FOR GAP BETWEEN CLOSED LATCH AND TOP OF HORN OR COUPLING BALL. **DO NOT USE IF GAP IS 3/8 IN. OR MORE.**
- (5) MAKE SURE COUPLING IS LATCHED AND THAT LATCH WILL NOT OPEN.
- (6) PRIOR TO USE, ALWAYS CONNECT SAFETY CHAINS OF ADEQUATE STRENGTH FOR LOAD(S) BEING TOWED.
- (7) DO NOT BIND-UP (JACKKNIFE) ANY APPLICATION AS STRESSES CAN CAUSE DAMAGE TO THE COUPLING, DRAWBAR EYE, OTHER COMPONENTS OR ANY COMBINATION OF THEM. JACKKNIFING MAY RESULT IN FAILURE OF PRODUCTS OR COMPONENTS, RESULTING IN DETACHMENT OF THE TRAILER WHILE IN USE.
- (8) DO NOT APPLY LUBRICANTS TO THE COUPLING HOOK OR DRAWBAR EYE LOOP, AS THEY CAN COVER UP POSSIBLE DAMAGE AND ACCELERATE WEAR.
- (9) ALWAYS ABIDE BY ALL APPLICABLE STATE AND FEDERAL REGULATIONS GOVERNING SAFE AND PROPER TRANSPORTATION.
- (10) NEVER STRIKE ANY OF THESE COMPONENTS WITH A HAMMER OR ANY OTHER DEVICE.
- (11) ALWAYS VERIFY PROPER OPERATION OF LATCHING SYSTEM AND COUPLING COMPONENTS PRIOR TO DRIVE OFF.
- (12) NEVER USE A COUPLING THAT YOU DO NOT FULLY UNDERSTAND HOW TO PROPERLY OPERATE AND VERIFY SECURE LATCHING OF.
- (13) **NEVER REPLACE ANY PART IN ANY OF PREMIER'S ASSEMBLIES WITH NON-PREMIER COMPONENTS. DOING SO WILL VOID ALL WARRANTY AND POTENTIALLY COMPROMISE THE UNIT'S INTEGRITY, WHICH COULD RESULT IN PROPERTY DAMAGE, SERIOUS INJURY, OR DEATH.**



WARNING!

Important

Installation Instructions:
Do NOT attempt install
without first reading all
attached instructions.

Installation must be
performed by a qualified
mechanic only.



PREMIER MANUFACTURING COMPANY
THE FIRST NAME IN QUALITY COUPLINGS
800-255-5387 (503) 234-9202
www.premier-mfg.com

2200PK-ELL Service Guidelines
Revised: 11/13

WARRANTY: We warrant all Premier products to be free from defects in material or workmanship for one year. We will repair or replace, at our option, any Premier product which our examination reveals to be defective, provided that the product is returned to our factory, at Tualatin, Oregon transportation prepaid, within one year of purchase by the first retail purchaser. Our warranty does not extend to products which have been subject to misuse, neglect, improper installation, maintenance or application, nor does our warranty extend to products which have been repaired or altered outside of Premier's facility unless the repair or alteration has been expressly authorized in writing by Premier. ***This warranty is in lieu of all other warranties, express or implied, and excludes warranties of merchantability, fitness for a particular purpose and otherwise, and in no event will Premier be liable for incidental, special, contingent or consequential damages.***

DISCLAIMER: Although great care has been taken to ensure accurate information throughout this document, Premier Manufacturing Company must reserve the right to alter any information contained within. These changes include but are not limited to: Dimensional changes, load capacity and availability of any part or assembly.

© 2009 Premier Manufacturing Company

All rights reserved. Any reproduction of the photographic images or any other portion of this document, including but not limited to the photocopying, or retention and/or storage in a retrieval system of any kind, is strictly prohibited without prior express written permission from Premier Manufacturing Company.

