

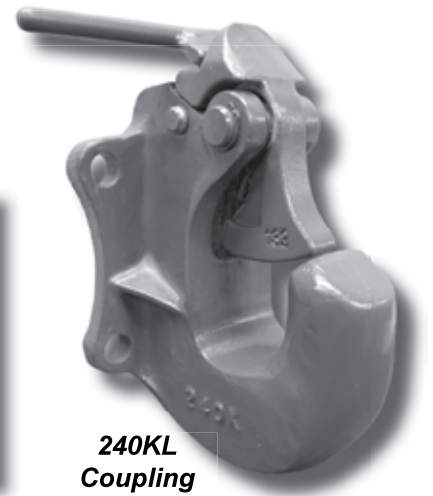

PREMIER

THE FIRST NAME IN QUALITY COUPLINGS



240KL
Coupling

133KL Left Bar Latch Lock Installation Guidelines

for 240K Coupling

Replacing the 133 Latch Lock with the 133KL Left Bar Latch Lock

BEFORE GETTING STARTED:

- ▶ The following instructions are intended for a 240K coupling sitting vertical and upright on a flat work surface with the front facing toward you and the mounting base facing away.
- ▶ **CAUTION:** When removing and replacing snap rings the appropriate snap ring plier tools are necessary. Do not attempt removal or replacement without the correct snap ring plier tools. In addition, use caution when removing and replacing snap rings – Do not over expand them as damage could result. Also, when assembling a snap ring into position - Make certain that the snap ring is fully seated into the groove.
- ▶ Safety glasses are required for all of the following procedures.

DISASSEMBLY

- 1) Prior to and during disassembly, familiarize yourself with the location of the various parts in the 240K Coupling. This will assist in the assembly process. (See Photo Reference Page for part numbers.)
- 2) Locate the 131 Pin and remove the right 144-75 Snap Ring. Slide the 131 Pin to the left and remove it from the coupling body.
- 3) **CAUTION:** The 132A spring is loaded and will likely spring out if not held on to. Grasp the bottom of the 132 Latch and 132A Spring. Rotate the 133 Latch Lock to the fully opened position and hold.
- 4) Remove the 132 Latch and 132A Spring from the body. Release the 133 latch lock. The 132B Bushing should be residing within the right inside of the 132 Latch.
- 5) Locate the 134 Pin and remove the left 275-50 Snap Ring.
- 6) **CAUTION:** The 133A Spring is loaded and will likely spring out if not held on to. While holding the 133 Latch Lock, remove the 134 Pin by pulling it out of the coupling body from the right side.
- 7) Remove the 133 Latch Lock and 133A Spring. Remove the 134B Bushing from the left side of the 133 Latch Lock. This will be used in the 133KL when reassembling. Discard the 133 Latch Lock, as it will not be used in reassembly.

DISASSEMBLY IS COMPLETE

IMPORTANT NOTES TO CLEAN, INSPECT & LUBRICATE:

- ▶ Use only genuine PREMIER replacement parts on any repairs. Use of other parts, which can have different specifications or tolerances, may fail to alert you to non-obvious damage to the hitch which can lead to hitch failure.
- ▶ After disassembling, clean and inspect parts and body thoroughly for wear and/or damage. If wear exists or damage is noted, replace affected part(s). NEVER ATTEMPT WELD REPAIR OF ANY DAMAGED OR WORN COMPONENT. (Field or shop weld repairs are inadequate, and may further weaken the coupling.)
- ▶ Make certain that all areas are clean and grit free. All body holes, part holes and pins need to be lubricated with a heavy grease before the parts are reassembled. (DO NOT LUBRICATE PINTLE HOOK WEAR SURFACE.)
- ▶ Do not use solvents on the 132B or 134B bushings, as it could damage them.
- ▶ Clean, inspect and lubricate latch components every 90 days or sooner if required by the operating



environment.

- ▶ Clean and inspect the coupling for damage and excessive wear prior to each and every use.
- ▶ Do not over-tighten fasteners as this may cause damage.

ASSEMBLY

- 1) Install the 134B Bushing into the left side hole of the 133KL Left Bar Latch Lock part.
- 2) From the right side of the coupling, slightly insert the 134 Pin into the body hole until approx 1/4" is visibly protruding into the inside of the right body wall.
- 3) Hold the 133A Spring, with the hooked leg angled horizontal to the left and the straight leg directed away from you. Insert it into the body and onto the 134 Pin with the straight leg resting on top of the inside body ledge (see Photo #1).
- 4) Insert the 134B Bushing into the left side hole of the 133KL Left Bar Latch Lock (the side with the bar on it). Push it in fully until the flange is flush with the surface.
- 5) With the bar pointing left, place the 133KL Left Bar Latch Lock into top of coupling with hooked leg of spring going behind, across the back of the 133KL. Also, make certain that the straight leg of the 133A Spring remains on the body wall ledge. With the holes aligned, push 134 Pin through and out the left side of the coupling body. Be careful not to force the pin, as damage to the bushing can occur.
- 6) The 133KL should be spring loaded forward (see Photo #2). Rotate the 133KL back and forth checking for smoothness and increasing spring force as it is rotated backwards. Replace the 275-50 Snap Ring on left end of 134 Pin, making sure that it is fully seated down into the slot.
- 7) From the left side of the coupling, slightly insert the 131 Pin into the body hole until approx 3/16" is protruding into the inside of the left body wall.
- 8) Hold the 132A Spring with the straight leg directed away from you and the hooked leg coming toward you and hooked to the right. Place it onto the 131 pin in this orientation (see Photo #3).

- 9) Verify that the 132B Bushing is still located in the right side hole of the 132 Latch. If not, fully insert it until the flange is flush with the surface.
- 10) With left hand, rotate the 133KL Left Bar Latch Lock backwards and hold. Slide the 132 Latch into the body so that the hooked spring leg wraps around the back of the 132 Latch, and line up the hole with the 131 Pin (see Photo #4).
- 11) Being cautious not to jam the 132B Bushing, push the 131 Pin through the 132 Latch hole and out the right side. Due to the snug fit caused by the 132B Bushing, it is possible that while pushing the 131 Pin into place, you may have to rotate the pin and wiggle the 132 Latch to get everything to line up properly. Do not hammer or tap the pin through. This action could damage the bushing.
- 12) Replace the 144-75 Snap Ring on right end of 131 Pin, making sure that it is fully seated down into the slot.
- 13) Test the coupling for proper operation, by opening and closing it several times.
- 14) If the coupling operates smoothly and correctly, it is ready to be mounted onto the vehicle and put into service. If the coupling does not operate smoothly, DO NOT use the coupling until the problem has been identified and rectified.

WARNING:

Do NOT bind-up (jackknife) any application, as stresses can cause damage to the hitch, drawbar eye, other components or any combination of them. Jackknifing may result in failure of products or components, resulting in detachment of the trailer while in use.



PHOTO REFERENCE PAGE

Model 240K parts available:

- 131: Pin
 - 132: Latch
 - 132B: Bushing
 - 132A: Spring
 - 133: Latch Lock
 - 133A: Spring
 - 134: Pin
 - 134B: Bushing
 - 144-75: Snap Ring (2)
 - 275-50: Snap Ring (2)
- *133KL: Left Bar Latch Lock
 *Available as a separate part.



PHOTO #1

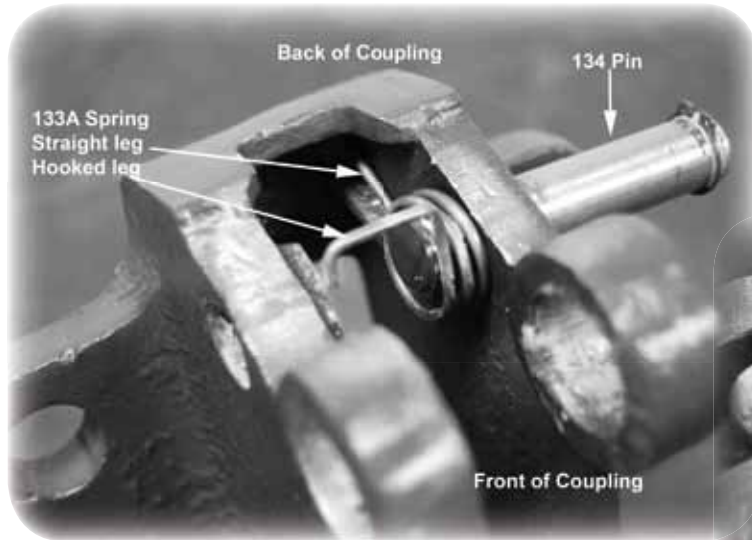

PHOTO #2

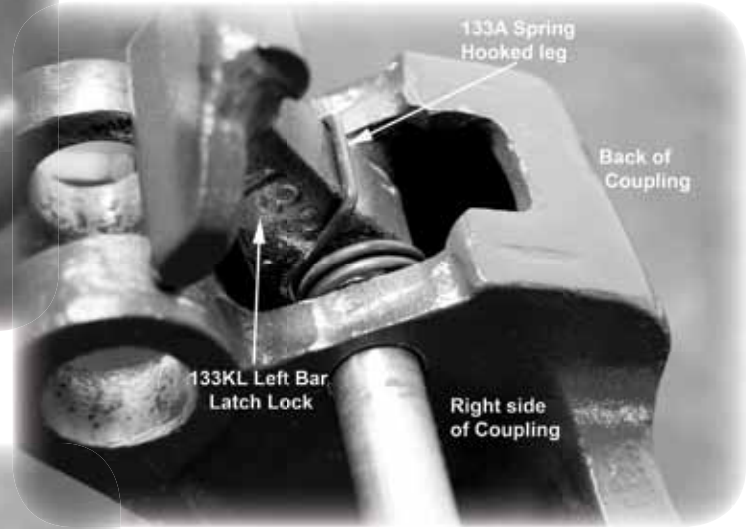

PHOTO #3

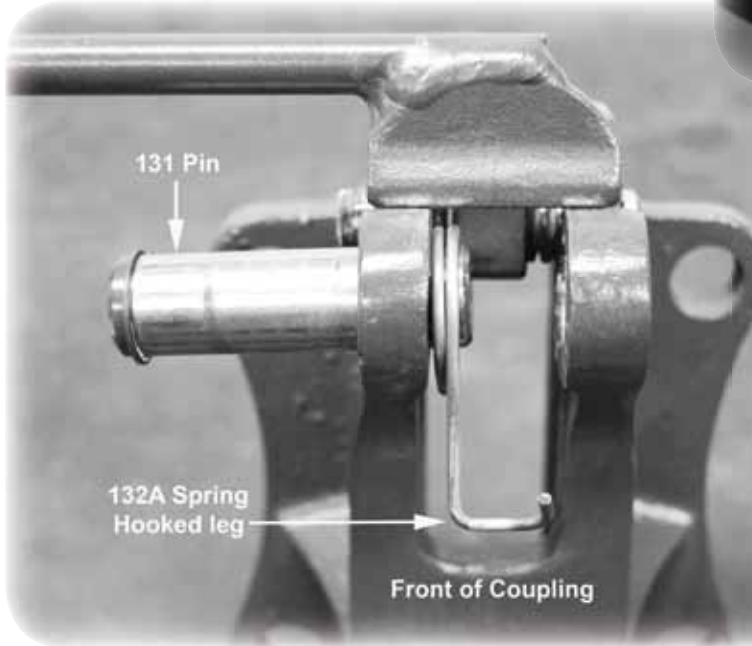
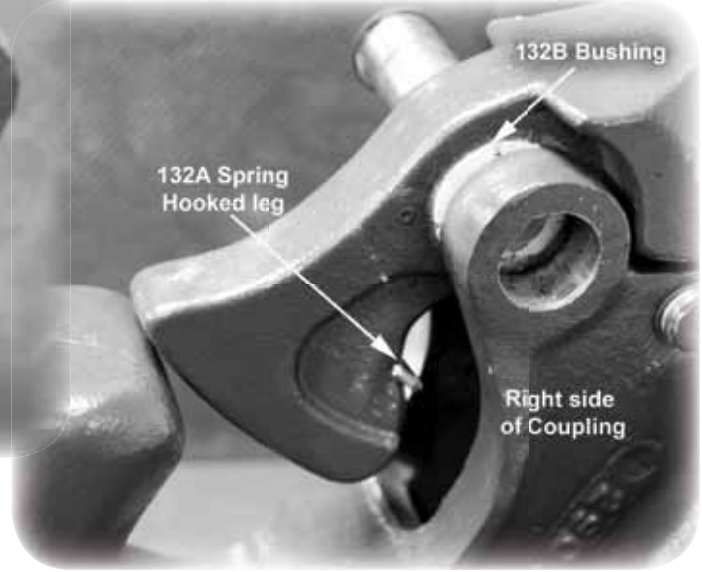

PHOTO #4



CONTINUE TO NEXT PAGE FOR
IMPORTANT INFORMATION.



ATTENTION !

End Users must read and follow this information.

DISTRIBUTORS & OEM'S: Please ensure that your customers are made aware of the following information on this page.

- (1) **VERIFY THAT BOTH COUPLING'S AND DRAWBAR EYE'S RATED CAPACITIES MEET YOUR APPLICATION(S) REQUIREMENTS.**
- (2) DO NOT OVERLOAD COUPLING OR DRAWBAR EYE.
- (3) INSPECT COUPLING, LATCH AND DRAWBAR EYE FOR CRACKS, BENDING DAMAGE OR EXCESSIVE WEAR. **DO NOT USE IF ANY OF THESE CONDITIONS EXIST!**
- (4) CHECK FOR GAP BETWEEN CLOSED LATCH AND TOP OF HORN OR COUPLING BALL. **DO NOT USE IF GAP IS 3/8 IN. OR MORE.**
- (5) MAKE SURE COUPLING IS LATCHED AND THAT LATCH WILL NOT OPEN.
- (6) PRIOR TO USE, ALWAYS CONNECT SAFETY CHAINS OF ADEQUATE STRENGTH FOR LOAD(S) BEING TOWED.
- (7) DO NOT BIND-UP (JACKKNIFE) ANY APPLICATION AS STRESSES CAN CAUSE DAMAGE TO THE COUPLING, DRAWBAR EYE, OTHER COMPONENTS OR ANY COMBINATION OF THEM. JACKKNIFING MAY RESULT IN FAILURE OF PRODUCTS OR COMPONENTS, RESULTING IN DETACHMENT OF THE TRAILER WHILE IN USE.
- (8) DO NOT APPLY LUBRICANTS TO THE COUPLING HOOK OR DRAWBAR EYE LOOP, AS THEY CAN COVER UP POSSIBLE DAMAGE AND ACCELERATE WEAR.
- (9) ALWAYS ABIDE BY ALL APPLICABLE STATE AND FEDERAL REGULATIONS GOVERNING SAFE AND PROPER TRANSPORTATION.
- (10) NEVER STRIKE ANY OF THESE COMPONENTS WITH A HAMMER OR ANY OTHER DEVICE.
- (11) ALWAYS VERIFY PROPER OPERATION OF LATCHING SYSTEM AND COUPLING COMPONENTS PRIOR TO DRIVE OFF.
- (12) NEVER USE A COUPLING THAT YOU DO NOT FULLY UNDERSTAND HOW TO PROPERLY OPERATE AND VERIFY SECURE LATCHING OF.
- (13) **NEVER REPLACE ANY PART IN ANY OF PREMIER'S ASSEMBLIES WITH NON-PREMIER COMPONENTS. DOING SO WILL VOID ALL WARRANTY AND POTENTIALLY COMPROMISE THE UNIT'S INTEGRITY, WHICH COULD RESULT IN PROPERTY DAMAGE, SERIOUS INJURY, OR DEATH.**



WARNING!

Important

**Installation Instructions:
Do NOT attempt install
without first reading all
attached instructions.
Installation must be
performed by a qualified
mechanic only.**



PREMIER MANUFACTURING COMPANY
THE FIRST NAME IN QUALITY COUPLINGS
800-255-5387 (503) 234-9202
www.premier-mfg.com

133KL Installation Guidelines
Revised: 01/2010

WARRANTY: We warrant all Premier products to be free from defects in material or workmanship for one year. We will repair or replace, at our option, any Premier product which our examination reveals to be defective, provided that the product is returned to our factory, at Tualatin, Oregon transportation prepaid, within one year of purchase by the first retail purchaser. Our warranty does not extend to products which have been subject to misuse, neglect, improper installation, maintenance or application, nor does our warranty extend to products which have been repaired or altered outside of Premier's facility unless the repair or alteration has been expressly authorized in writing by Premier. ***This warranty is in lieu of all other warranties, express or implied, and excludes warranties of merchantability, fitness for a particular purpose and otherwise, and in no event will Premier be liable for incidental, special, contingent or consequential damages.***

DISCLAIMER: Although great care has been taken to ensure accurate information throughout this document, Premier Manufacturing Company must reserve the right to alter any information contained within. These changes include but are not limited to: Dimensional changes, load capacity and availability of any part or assembly.

© 2009 Premier Manufacturing Company

All rights reserved. Any reproduction of the photographic images or any other portion of this document, including but not limited to the photocopying, or retention and/or storage in a retrieval system of any kind, is strictly prohibited without prior express written permission from Premier Manufacturing Company.

