



PREMIER MANUFACTURING CO.

THE FIRST NAME IN QUALITY COUPLINGS

Installation, Inspection, Operation & Maintenance Guide



Model 570 Coupling

IMPORTANT

Read these instructions completely before installing, using or attempting to repair this product. If you have any questions, call Premier at (800) 255-5387 or (503) 234-9202.

Selecting The Right Equipment

Whatever your application, selecting the proper equipment for the job is very important. Proper selection along with regular inspection and maintenance will help keep operating costs minimal while providing long life to each component. Below are general guidelines for selecting Premier Couplings and Drawbar Eyes. If you feel that your application is unique, please give Premier a call so that we may help you through the selection process.

Follow these four steps to ensure proper selection of Premier Couplings and Drawbar Eyes.

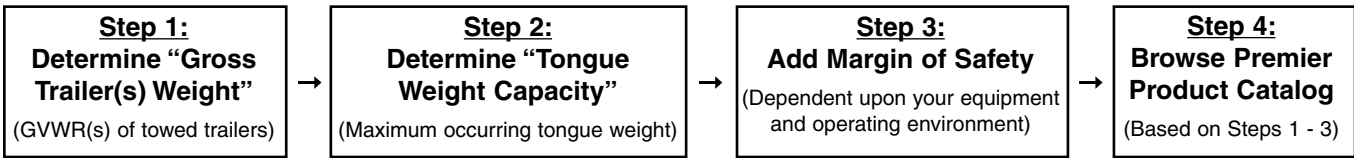

Step 1: Determine "Gross Trailer(s) Weight"

"Gross Trailer(s) Weight" is usually determined by the Gross Vehicle Weight Rating (GVWR). This information is attached to the trailer by the trailer manufacturer.

Double Trailer Configuration



Example only, each application may vary and should be considered unique.

For "Double Trailer" configurations, only the rear trailer is considered when selecting your Premier Coupling or Drawbar Eye. In this example, a Coupling and Drawbar Eye with a "Gross Trailer Weight" rating of 40,000 lbs. (18,143 kg) would be the minimum rating acceptable for normal, over-the-road applications (see Tongue Weight section below).

Triple Trailer Configuration



Example only, each application may vary and should be considered unique.

For "Triple Trailers", only the two most rearward trailers are considered in selecting your Premier Coupling or Drawbar Eye. In this example, a Coupling and Drawbar Eye with a "Gross Trailer Weight" rating of 80,000 lbs. (36,287 kg) would be the minimum acceptable for normal, over-the-road applications (see Tongue Weight section below).

Step 2: Determine "Tongue Weight Capacity"



"Tongue Weight Capacity" is the maximum expected weight at the drawbar eye. If a hinged drawbar is used, the maximum weight will be approximately 1/2 the overall drawbar weight. If a non-hinged drawbar is used and the actual tongue weight is not known, you can approximate the weight by multiplying the GVWR of the towed trailer by 15%. However, each application is unique and the best practice is to weigh the tongue when the trailer is loaded to its GVWR.

Step 3: Considering Operating Conditions and Environments

Environments such as rough uneven roads or off-road use can dramatically increase shock loads to both drawbar eyes and couplings. In general, increasing the "Gross Trailer Weight" (Step 1:) and "Tongue Weight Capacity" (Step 2:) by a minimum of 25% will be sufficient for many applications. Even if an application is used off-road occasionally, the minimum increase necessary for Gross Trailer and Tongue Weight is 25%. Certain types of equipment and/or operating practices can also dramatically increase loads through equipment binding and/or improper loading practices. Of special concern is high tongue weight. However, each application is unique and every environment different, therefore your application may require more than 25%.

Once both "Gross Trailers(s) Weight" (Step 1:) and "Tongue Weight Capacity" (Step 2:) have been determined, evaluate your operating conditions and apply an appropriate margin of safety.

Step 4: Browse Premier Product Catalog

Browse the Premier Product Catalog and refer to the "Specifications" section of each product. Be sure to review the "Understanding Premier Load Specifications" section and "Coupling to Drawbar Eye Cross-Reference" sheet on the next couple pages.



Selecting The Right Equipment

Understanding Premier Load Specifications

Each Premier product undergoes extensive design and testing prior to being introduced. We use the latest in Computer Aided Design and Analysis Software as well as physical destructive tests. Premier's published load specifications are the maximum load a given product or part will withstand without failure. Premier's testing procedures closely follow the Society of Automotive Engineers (SAE) guidelines of Recommended Practice for testing Couplings and Drawbar Eyes (SAE J847 & J849).

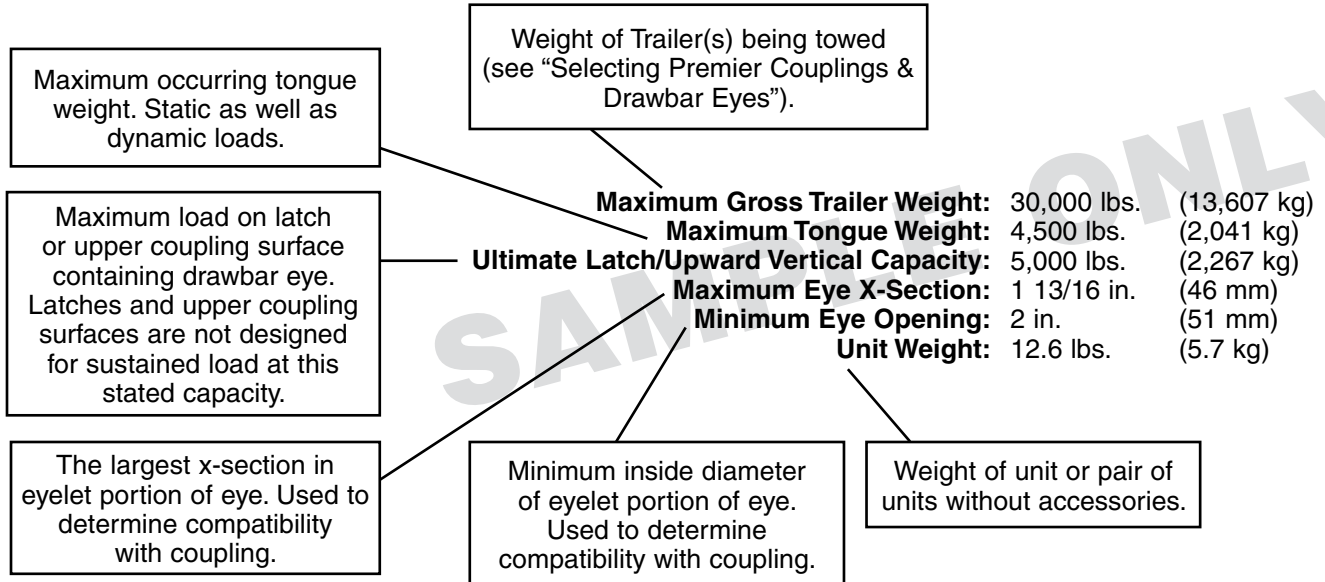

Importance of Inspection and Maintenance

Whether you use Premier Jacks, Couplings, Drawbar Eyes, Hinge Assemblies or any other Premier product, regular inspection and maintenance are essential for proper function, keeping repair costs to a minimum and above all, safe and efficient operation.

To determine wear limits, Premier created Wear Gages that help judge the useful life of couplings and drawbar eyes (details in catalog). In accordance with Premier and the Federal Motor Carrier Safety Regulations, these were designed to identify wear at the critical percentages of 18% and 20%, by measuring the cross-section of coupling hooks (horn) and drawbar eye loops. 18% wear indicates that the product should be replaced as soon as possible. At 20% wear, the product is no longer in usable condition and must be taken out of service immediately and replaced. The latch gage bar measures the gap space between the top of the coupling hook and the closed latch. If the 3/8" latch gage bar can pass between this region, then the latch components should be considered worn past safe limits and replaced. Please note that these wear gage specifications are in accordance with Premier Mfg. Co. and the Federal Motor Carrier Safety Regulations (refer to other manufacturer's specifications for wear limits on their products).



Premier also provides Installation Guides for each of our major products. These help guide you through installation, inspection, routine maintenance and part replacement. Another resource is our website at www.premier-mfg.com. Here you will find Installation Guides, Service Guides, distributor locations, online catalogs, product information, trade show schedules and links to trucking resources.

"Premalloy" - Premier's Exclusive Alloy



"The harder you work it, the harder it gets" best describes how Premalloy performs. Premalloy actually work hardens at the contact surfaces during normal use, which results in longer service life. Premalloy is highly recommended for off-road and aggregate type applications due to its wear resistant characteristics. Many of Premier's couplings are made from this exclusive material. As you are browsing the catalog, look for the Premalloy icon next to the product photos to determine which models are made of this material.



Selecting The Right Equipment

Coupling to Drawbar Eye Cross Reference Chart

		Drawbar Eyes																																			
		2*	3	4	5	6/6A	8	11	20	21	22	23	107	108	110	123	125	126	127	200	200L	203	205	207	238DB†	245DB†	245DB-3†	300	304	305	306	307	309	405	407SE	410	
16	•	•																																			
24	•																																				
40	•																																				
100†			•	•	•	•	•	•	•	•	•	•	•	•	•	•	•	•	•	•	•	•	•	•	•	•	•	•	•	•	•	•	•	•	•	•	
100-4†			•	•	•	•	•	•	•	•	•	•	•	•	•	•	•	•	•	•	•	•	•	•	•	•	•	•	•	•	•	•	•	•	•	•	
130	•	•	•	•	•	•	•	•	•	•	•	•	•	•	•	•	•	•	•	•	•	•	•	•	•	•	•	•	•	•	•	•	•	•	•	•	
135NT		•	•	•	•	•	•	•	•	•	•	•	•	•	•	•	•	•	•	•	•	•	•	•	•	•	•	•	•	•	•	•	•	•	•	•	
140	•	•					•																														
150			•	•	•	•	•	•	•	•	•	•	•	•	•	•	•	•	•	•	•	•	•	•	•	•	•	•	•	•	•	•	•	•	•	•	
160	•	•	•	•	•	•	•	•	•	•	•	•	•	•	•	•	•	•	•	•	•	•	•	•	•	•	•	•	•	•	•	•	•	•	•	•	
235NT			•	•	•	•	•	•	•	•	•	•	•	•	•	•	•	•	•	•	•	•	•	•	•	•	•	•	•	•	•	•	•	•	•	•	
240		•	•	•	•	•	•	•	•	•	•	•	•	•	•	•	•	•	•	•	•	•	•	•	•	•	•	•	•	•	•	•	•	•	•	•	
240K			•	•	•	•	•	•	•	•	•	•	•	•	•	•	•	•	•	•	•	•	•	•	•	•	•	•	•	•	•	•	•	•	•	•	
270			•	•	•	•	•	•	•	•	•	•	•	•	•	•	•	•	•	•	•	•	•	•	•	•	•	•	•	•	•	•	•	•	•	•	
290			•	•	•	•	•	•	•	•	•	•	•	•	•	•	•	•	•	•	•	•	•	•	•	•	•	•	•	•	•	•	•	•	•	•	
360			•	•	•	•	•	•	•	•	•	•	•	•	•	•	•	•	•	•	•	•	•	•	•	•	•	•	•	•	•	•	•	•	•	•	
370			•	•	•	•	•	•	•	•	•	•	•	•	•	•	•	•	•	•	•	•	•	•	•	•	•	•	•	•	•	•	•	•	•	•	
370B			•	•	•	•	•	•	•	•	•	•	•	•	•	•	•	•	•	•	•	•	•	•	•	•	•	•	•	•	•	•	•	•	•	•	
470			•	•	•	•	•	•	•	•	•	•	•	•	•	•	•	•	•	•	•	•	•	•	•	•	•	•	•	•	•	•	•	•	•	•	
470H			•	•	•	•	•	•	•	•	•	•	•	•	•	•	•	•	•	•	•	•	•	•	•	•	•	•	•	•	•	•	•	•	•	•	
480			•	•	•	•	•	•	•	•	•	•	•	•	•	•	•	•	•	•	•	•	•	•	•	•	•	•	•	•	•	•	•	•	•	•	
570			•	•	•	•	•	•	•	•	•	•	•	•	•	•	•	•	•	•	•	•	•	•	•	•	•	•	•	•	•	•	•	•	•	•	
580	•	•	•	•	•	•	•	•	•	•	•	•	•	•	•	•	•	•	•	•	•	•	•	•	•	•	•	•	•	•	•	•	•	•	•	•	
580J			•	•	•	•	•	•	•	•	•	•	•	•	•	•	•	•	•	•	•	•	•	•	•	•	•	•	•	•	•	•	•	•	•	•	
590	•	•	•	•	•	•	•	•	•	•	•	•	•	•	•	•	•	•	•	•	•	•	•	•	•	•	•	•	•	•	•	•	•	•	•	•	
690/690T			•	•	•	•	•	•	•	•	•	•	•	•	•	•	•	•	•	•	•	•	•	•	•	•	•	•	•	•	•	•	•	•	•	•	
770			•	•	•	•	•	•	•	•	•	•	•	•	•	•	•	•	•	•	•	•	•	•	•	•	•	•	•	•	•	•	•	•	•	•	
780			•	•	•	•	•	•	•	•	•	•	•	•	•	•	•	•	•	•	•	•	•	•	•	•	•	•	•	•	•	•	•	•	•	•	
790																									•		•	•	•	•	•	•	•	•	•	•	
880																									•		•	•	•	•	•	•	•	•	•	•	
890/890C			•	•	•	•	•	•	•	•	•	•													•	•	•	•	•	•	•	•	•	•	•	•	
2200			•	•	•	•	•	•	•	•	•	•	•	•	•	•	•	•	•	•	•	•	•	•	•	•	•	•	•	•	•	•	•	•	•	•	
2300			•	•	•	•	•	•	•	•	•	•	•	•	•	•	•	•	•	•	•	•	•	•	•	•	•	•	•	•	•	•	•	•	•	•	
2300B			•	•	•	•	•	•	•	•	•	•	•	•	•	•	•	•	•	•	•	•	•	•	•	•	•	•	•	•	•	•	•	•	•	•	
2400			•	•	•	•	•	•	•	•	•	•	•	•	•	•	•	•	•	•	•	•	•	•	•	•	•	•	•	•	•	•	•	•	•	•	
2400H			•	•	•	•	•	•	•	•	•	•	•	•	•	•	•	•	•	•	•	•	•	•	•	•	•	•	•	•	•	•	•	•	•	•	

† Saf-Tite Product

* Industrial Application

CAUTION: Verify that both the coupling's and drawbar eye's rated capacities meet your application(s) requirements.



Model 570 Coupling

SPECIFICATIONS AND LOAD CAPACITIES

SAFETY WARNING

This product is designed for towing under normal conditions within the stated gross trailer weight. Do not overload or abuse this product. Overloading or abuse may lead to property damage, severe injury, or death.

Gross Trailer Weight: 90,000 lbs. (40,823 kg)
Maximum Tongue Weight: 18,000 lbs. (8,164 kg)
Ultimate Latch Capacity: 20,000 lbs. (9,071 kg)
Maximum Eye X-Section: 1 13/16 in. (46 mm)
Minimum Eye Opening: 2 3/8 in. (60 mm)
Unit Weight: 32.8 lbs. (14.9 kg)

STANDARD INSTALLATION DRAWING

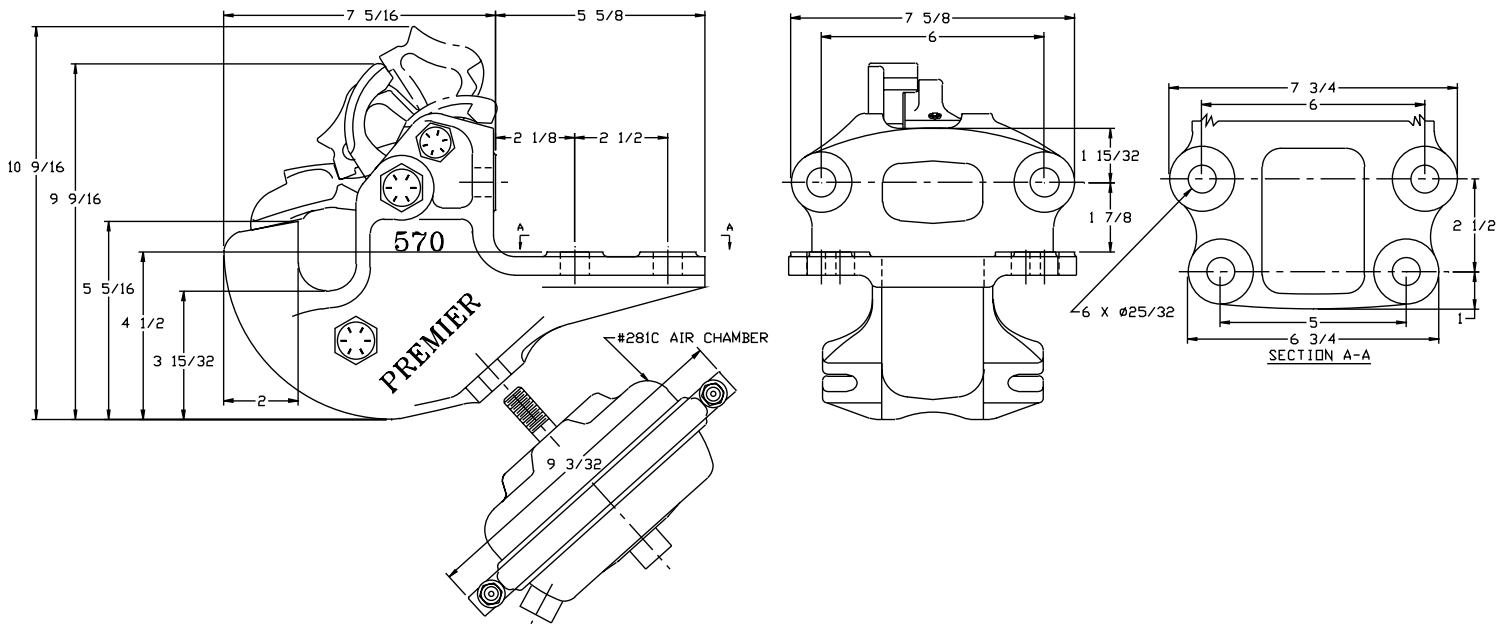

Pushrod length is 2 3/8 in. (60 mm).

REPLACEMENT PART INFORMATION

370PK Parts Kit Includes:

274A: Locknut	582A: Spring
372B: Locking Pawl	*376: Spring
373: Pawl	*271: Thimble
373A: Spring	*374: Bolt
373B: Spacer	*274A: Locknut
374: Bolt	*579: Shoe
375: Bolt	
375A: Locknut	
472: Latch	

*Not included in parts kit, available individually

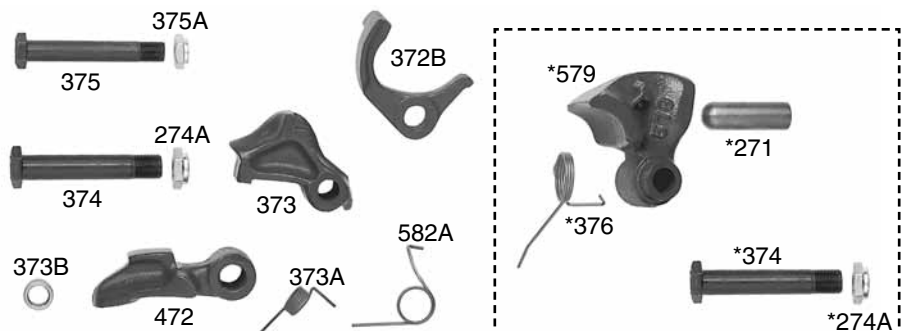

PARTS

Parts Included with 570A:

- 570 Coupling
- 504 Bolt Kit
- 281C Air Chamber
- 271 Thimble



Model 570 Coupling

ACCESSORIES

Optional Accessories:

- 282 Air Chamber (Type-30): Larger chamber diameter provides greater shoe force compared to the 281C Air Chamber.
- Thimbles: 271B (4 3/8 in. / 111 mm), 271C (5 1/2 in. / 140 mm)
- 378 Drawbar Guides: Helps guide drawbar eye into coupling.
- 14011 Wear Gage (2 in.): To determine hook wear limits.
- 14026 Latch Gage: To determine latch gap limit.

INSTALLATION

The 570 Coupling is only to be used and maintained with Premier parts listed in the Replacement Part Information section. Any substitution or use of non-Premier parts in a 570 Coupling will VOID ALL PRODUCT WARRANTY. This coupling must be used with an air chamber.

Installation Procedure:

1. The 570 Coupling must be installed to comply with the Federal Motor Carrier Safety Regulations. Specifically, Section 393.70, Paragraph C: "Towing of Full Trailers." Prior to install or operation, consult with local, State and Federal agencies, as there may be additional applicable laws governing installation and use of this product.
2. Make certain that the cross member the 570 Coupling is to be mounted on is of sufficient strength to withstand the load rating of the coupling.
3. Using the Standard Installation Drawing, measure and layout the cross member and then drill the holes for the mounting bolts.
4. Mount the 570 Coupling, 281C Air Chamber, and 271 Thimble as shown in the Standard Installation Drawing using either Premier's 504 Bolt Kit and provided torque value, or six other 3/4" grade-8 bolts and grade-C locknuts. Only use new fasteners when mounting couplings or drawbar eyes and torque to SAE specifications. **WARNING:** Never use an air chamber on a Premier coupling without a 271 series thimble.
5. Once mounted, check the latch components for proper operation and clearances (see the Inspection/Operation/Maintenance section for opening and closing the latch). If the operation of the latch components is sticky, lubricate all rotation points with a light penetrating oil. Work the latch assembly several times to distribute the lubricant evenly and remove any excess with a rag. Do not apply lubricant to the pintle/hook or saddle area of the 570 Coupling.
6. Plumb the air line to the 281C Air Chamber from the vehicle's emergency side air supply. NEVER use the service side air supply.
7. **WARNING!** Keep hands clear of the 570 Coupling during this test. Activate the emergency side air supply by releasing the emergency brake and visually verify that the 579 Shoe fully rotates toward the pintle.
9. If the 579 Shoe does not move, verify that the Air Chamber has been connected to the emergency side air supply and that the pushrod length is correct.
10. When the emergency side air supply is removed, the shoe should completely retract. Please note: The 579 Shoe acts as a shock absorbing device to help smooth the ride between vehicles. It is not considered part of the latching mechanism.
11. An "IMPORTANT WARNINGS!" sticker was enclosed. This must be attached to the coupling or cross member and be visible for the end user to read.



Model 570 Coupling

INSPECTION / OPERATION / MAINTENANCE

Inspection and Maintenance:

1. Visually inspect the coupling body and latch components for cracks, impact damage and/or deformation before each and every use. Do NOT use if any of these conditions exist.
2. Check the gap between the 472 Latch and the top of the pintle/hook on the coupling body before each and every use. Lift up on the latch to remove any free play and measure the gap. A gap of 3/8" or more means the coupling must be taken out of service and repaired or replaced.
3. If the wear area on the pintle/hook has worn 20% or more from its original cross-section, the coupling is considered out-of-service and must NOT be used.
4. Lubrication of the latch components must be performed at 90-day intervals or sooner depending on the operating environment.
5. Lubricate the latch components with a spray-type lubricant to evenly coat all rotation points. Rotate each latch component several times to evenly distribute the lubricant.
6. Remove any excess lubricant with a rag. Do not apply lubricant to the pintle/hook or saddle area of the coupling.
7. Never weld on any Premier part in order to repair damaged or worn areas. Field and/or shop welds are inadequate and may further weaken the coupling.
8. **WARNING:** Other inspection and maintenance procedures are also required prior to the operation of combination vehicles. Consult and follow all Federal Motor Carrier Safety Regulations as well as local, state and federal guidelines.

Operation:

OPENING Coupling Latch:

1. With the right hand or thumb, rotate the 372B Locking Pawl up and toward the mounting structure until full rotational travel is reached.
2. Holding the 372B Locking Pawl in place, rotate the 373 Pawl up until it stops on the locking pawl. Hold the pawl in this position.
3. Rotate the 472 Latch upward until it stops in the fully open position and hold.
4. Slowly release the 373 Pawl. The underside ledge on the pawl will catch the flat front surface of the 472 Latch, interlocking the two in the open position. The 570 Coupling is now open and ready to couple or uncouple.
5. lubricate the rotation point prior to further use (see the Inspection and Operation section).
6. Release the 373 Pawl. It will swiftly rotate down and engage the 472 Latch at its matching machined face. The 372B Locking Pawl will also rotate down into its closed position in the recessed pocket of the pawl. The 570 Coupling latch is now closed.
7. Verify for proper latching by applying an upward force to the bottom of the 472 Latch. There should be minimal movement and the LATCH SHOULD NOT OPEN! If the latch does not stay closed, do not use until it has been repaired or replaced.
8. This product is designed to be operated within its free rotation limits. It is the responsibility of the vehicle designer/end user to ensure that these limits are not exceeded (do not bind-up/jackknife).
9. **WARNING:** Prior to towing, make certain that adequately rated safety chains have been properly connected.

CLOSING Coupling Latch:

5. Rotate the 373 Pawl toward the mounting plate to the fully open position, releasing the 472 Latch.
6. The 472 Latch should rotate freely down until stopped by the top of the pintle. If it does not freely rotate down by itself, inspect, clean and

IMPORTANT GUIDELINES that apply to all Premier Air Adjusted Couplings

- Do not weld on any coupling assembly
- Always use Grade-8 fasteners properly torqued
- Do not apply lubricants to the coupling hook
- Air service chamber must be Type-24 or Type-30 with 90-120 PSI air supply
- Clean & inspect coupling for damage & excessive wear prior to each and every use
- Lubricate all coupling components at a minimum of 90 day intervals
- Do not bind-up (Jackknife) any application as stresses can cause damage to products or components, resulting in failure and detachment of the trailer while in use



CONTINUE TO NEXT PAGE FOR
IMPORTANT INFORMATION.



ATTENTION !

End Users must read and follow this information.

DISTRIBUTORS & OEM'S: Please ensure that your customers are made aware of the following information on this page.

- (1) **VERIFY THAT BOTH COUPLING'S AND DRAWBAR EYE'S RATED CAPACITIES MEET YOUR APPLICATION(S) REQUIREMENTS.**
- (2) DO NOT OVERLOAD COUPLING OR DRAWBAR EYE.
- (3) INSPECT COUPLING, LATCH AND DRAWBAR EYE FOR CRACKS, BENDING DAMAGE OR EXCESSIVE WEAR. **DO NOT USE IF ANY OF THESE CONDITIONS EXIST!**
- (4) CHECK FOR GAP BETWEEN CLOSED LATCH AND TOP OF HORN OR COUPLING BALL. **DO NOT USE IF GAP IS 3/8 IN. OR MORE.**
- (5) MAKE SURE COUPLING IS LATCHED AND THAT LATCH WILL NOT OPEN.
- (6) PRIOR TO USE, ALWAYS CONNECT SAFETY CHAINS OF ADEQUATE STRENGTH FOR LOAD(S) BEING TOWED.
- (7) DO NOT BIND-UP (JACKKNIFE) ANY APPLICATION AS STRESSES CAN CAUSE DAMAGE TO THE COUPLING, DRAWBAR EYE, OTHER COMPONENTS OR ANY COMBINATION OF THEM. JACKKNIFING MAY RESULT IN FAILURE OF PRODUCTS OR COMPONENTS, RESULTING IN DETACHMENT OF THE TRAILER WHILE IN USE.
- (8) DO NOT APPLY LUBRICANTS TO THE COUPLING HOOK OR DRAWBAR EYE LOOP, AS THEY CAN COVER UP POSSIBLE DAMAGE AND ACCELERATE WEAR.
- (9) ALWAYS ABIDE BY ALL APPLICABLE STATE AND FEDERAL REGULATIONS GOVERNING SAFE AND PROPER TRANSPORTATION.
- (10) NEVER STRIKE ANY OF THESE COMPONENTS WITH A HAMMER OR ANY OTHER DEVICE.
- (11) ALWAYS VERIFY PROPER OPERATION OF LATCHING SYSTEM AND COUPLING COMPONENTS PRIOR TO DRIVE OFF.
- (12) NEVER USE A COUPLING THAT YOU DO NOT FULLY UNDERSTAND HOW TO PROPERLY OPERATE AND VERIFY SECURE LATCHING OF.
- (13) **NEVER REPLACE ANY PART IN ANY OF PREMIER'S ASSEMBLIES WITH NON-PREMIER COMPONENTS. DOING SO WILL VOID ALL WARRANTY AND POTENTIALLY COMPROMISE THE UNIT'S INTEGRITY, WHICH COULD RESULT IN PROPERTY DAMAGE, SERIOUS INJURY, OR DEATH.**



WARNING!

This envelope contains important instructions AND MUST REMAIN ATTACHED TO THIS COUPLING. It may be removed only by the End User or by an Original Equipment Manufacturer who preserves this envelope and instructions and provides it to the end user.



PREMIER MANUFACTURING COMPANY
THE FIRST NAME IN QUALITY COUPLINGS
800-255-5387 (503) 234-9202
www.premier-mfg.com

Model 570 Coupling
Installation, etc.
Revised: 10/09

WARRANTY: We warrant all Premier products to be free from defects in material or workmanship for one year. We will repair or replace, at our option, any Premier product which our examination reveals to be defective, provided that the product is returned to our factory, at Tualatin, Oregon transportation prepaid, within one year of purchase by the first retail purchaser. Our warranty does not extend to products which have been subject to misuse, neglect, improper installation, maintenance or application, nor does our warranty extend to products which have been repaired or altered outside of Premier's facility unless the repair or alteration has been expressly authorized in writing by Premier. ***This warranty is in lieu of all other warranties, express or implied, and excludes warranties of merchantability, fitness for a particular purpose and otherwise, and in no event will Premier be liable for incidental, special, contingent or consequential damages.***

DISCLAIMER: Although great care has been taken to ensure accurate information throughout this document, Premier Manufacturing Company must reserve the right to alter any information contained within. These changes include but are not limited to: Dimensional changes, load capacity and availability of any part or assembly.

© 2009 Premier Manufacturing Company

All rights reserved. Any reproduction of the photographic images or any other portion of this document, including but not limited to the photocopying, or retention and/or storage in a retrieval system of any kind, is strictly prohibited without prior express written permission from Premier Manufacturing Company.

